

## LATCH HANDLE RELOCATOR KIT FOR 81-87 FULL SIZE CHEVY/GMC PICKUPS

This kit changes the tailgate latch handle to operate the tailgate latches from the inside or front face, of the tailgate. This modification requires cutting and drilling on the tailgate and should be installed before the tailgate cover. The suggested procedure is as follows.

1. Take the original tailgate off the truck and remove the handle, latches, and rods.
2. Assemble the new handle mechanism into the adapter plate as shown in the attached instructions.
3. Use the paper template as a guide for locating the area to be cut out on the front face, or inside surface, of the tailgate. Align the outline on the paper template to the embossed ribs on the tailgate. The top of the cutout area should be 6-1/2" below the top of the tailgate. Hold the paper flat even though the tailgate surface is curved. Secure it with masking tape. Be sure the cutout is centered between the embossed ribs in the tailgate surface.
4. Center punch through the paper to mark the corners of the area to be cut out. Remove the paper template and use a felt marking pen to draw four straight lines connecting the center punched corners of the area to be cut out. This is the outline of the opening for the new handle mechanism. The opening is **6" wide and 5" tall**.
5. Using a suitable saw, grinder, or perhaps a plasma cutter, cut out the rectangular opening marked in #4 above. The curved surface makes this difficult and a small grinder may be needed to smooth the opening.
6. Lay the assembled adaptor panel with handle over the opening in the position it will be mounted. Check the position of the adaptor panel to see that it is horizontally centered on the embossed pattern of the tailgate. It should fit on the flat area around the opening with the upper curved edge blending to the matching area on the tailgate. Check that there is clearance around the handle mechanism and that it will operate freely without rubbing the sheet metal. While holding the adaptor panel in its correct position, center punch the tailgate through two screw holes that are diagonally opposite each other in the adapter panel. Use a #24 or 5/32 drill and drill the tailgate.
7. Install the handle adaptor panel using phillips screws in the 2 holes drilled in #6 above. Mark the location of the remaining screw holes with a scribe or marking pen. Remove the panel and carefully center punch for each screw hole. Drill the holes with the #24 or 5/32 drill, being careful not to drill the holes oversize.
8. Install the adaptor panel again using all eight screws.
9. Lay the tailgate on a padded work surface with the rear or outside of the tailgate facing upward. Install the new rods on the latches so that the bent ends point toward the front of the truck. Slide the rods and latches into the tailgate from the ends and bolt the latches in position. The tips of the rods should be visible in the original tailgate handle opening near the new handle mechanism. If not, use a wire or needle nose plier to move the rod tips near the handle connectors.
10. Lift the rod tips and insert them into the plastic retainers on the handle mechanism. Snap the retainers over the rods and check that the handle operates the latches correctly. This would be a good time to temporarily mount the tailgate on the truck to check the operation of the latches and handle. After the tailgate cover is welded on it is more difficult to work on the handle assembly.
11. If the latches operate correctly, the handle relocator kit is completed. The tailgate is ready for a tailgate cover.

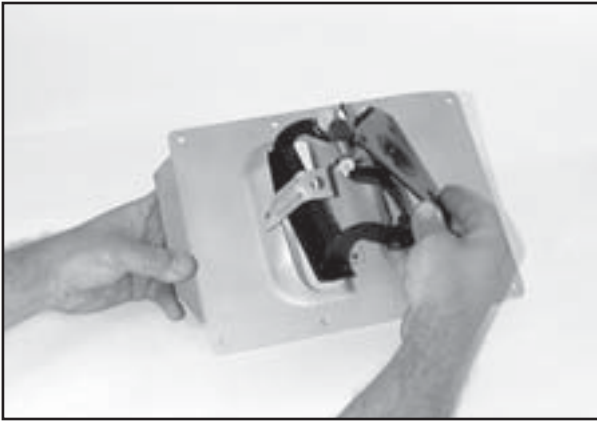

1. Hold the handle in the open position and while holding it open insert it into the opening from the back side. Be careful not to scratch the paint.

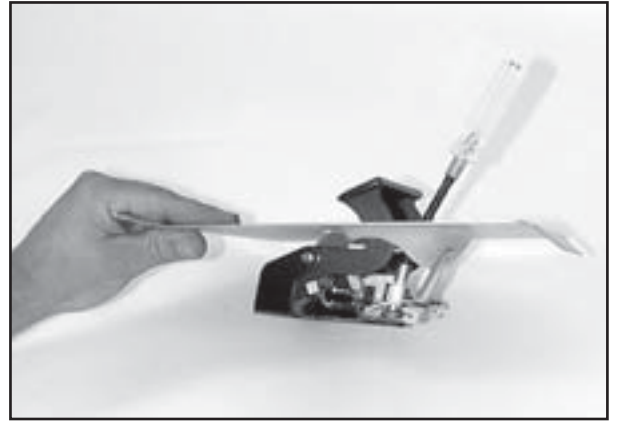

2. Use a cup washer and an 8mm hex head screw to attach the lower mounting point and the handle to the bracket on the adapter plate. Do not tighten the screw at this time.

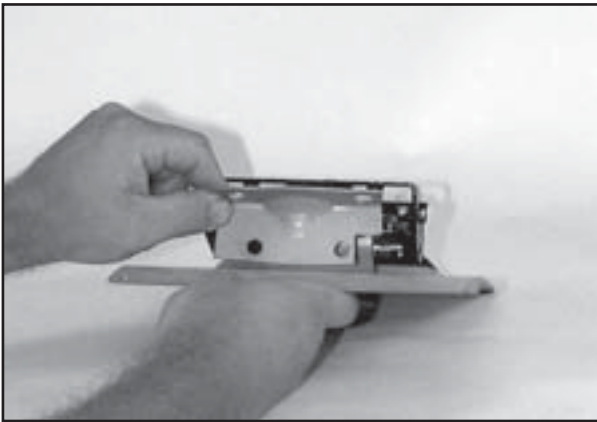

3. Insert the angle bracket between the upper two mounting points and the bracket welded to the adapter plate above the handle opening. The angle bracket should be positioned above the welded bracket.

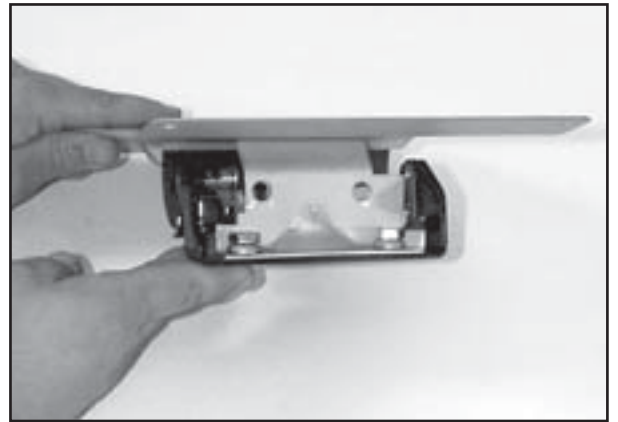

4. Use the two cup washers and 8mm hex head screws to attach the angle bracket to the upper two handle mounting points. Tighten the screws securely.

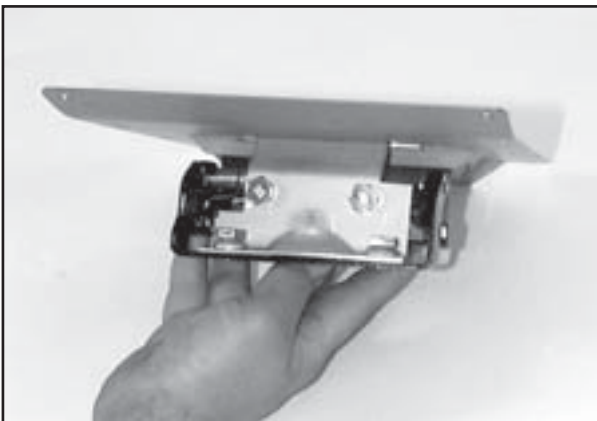

5. Attach the angle bracket to the welded bracket above the handle opening using two 8mm hex head screws and nuts. Tighten the bolts slightly to permit aligning the handle.

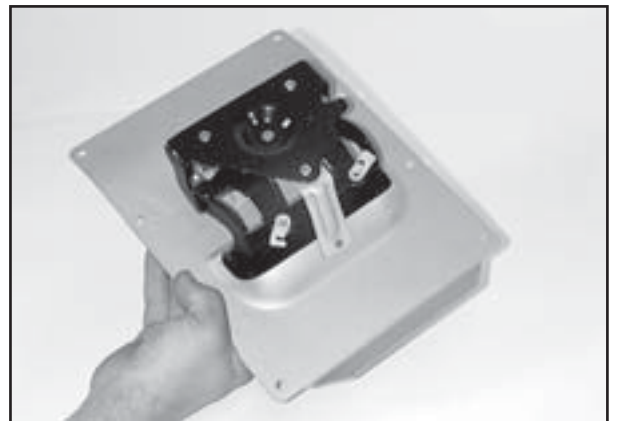

6. Shift the handle as needed to align it to the adapter plate opening. When the alignment is correct tighten all bolts. The assembly is ready to install.

# LATCH HANDLE RELOCATOR KIT FOR 81-87 CHEVY/GMC PICKUPS

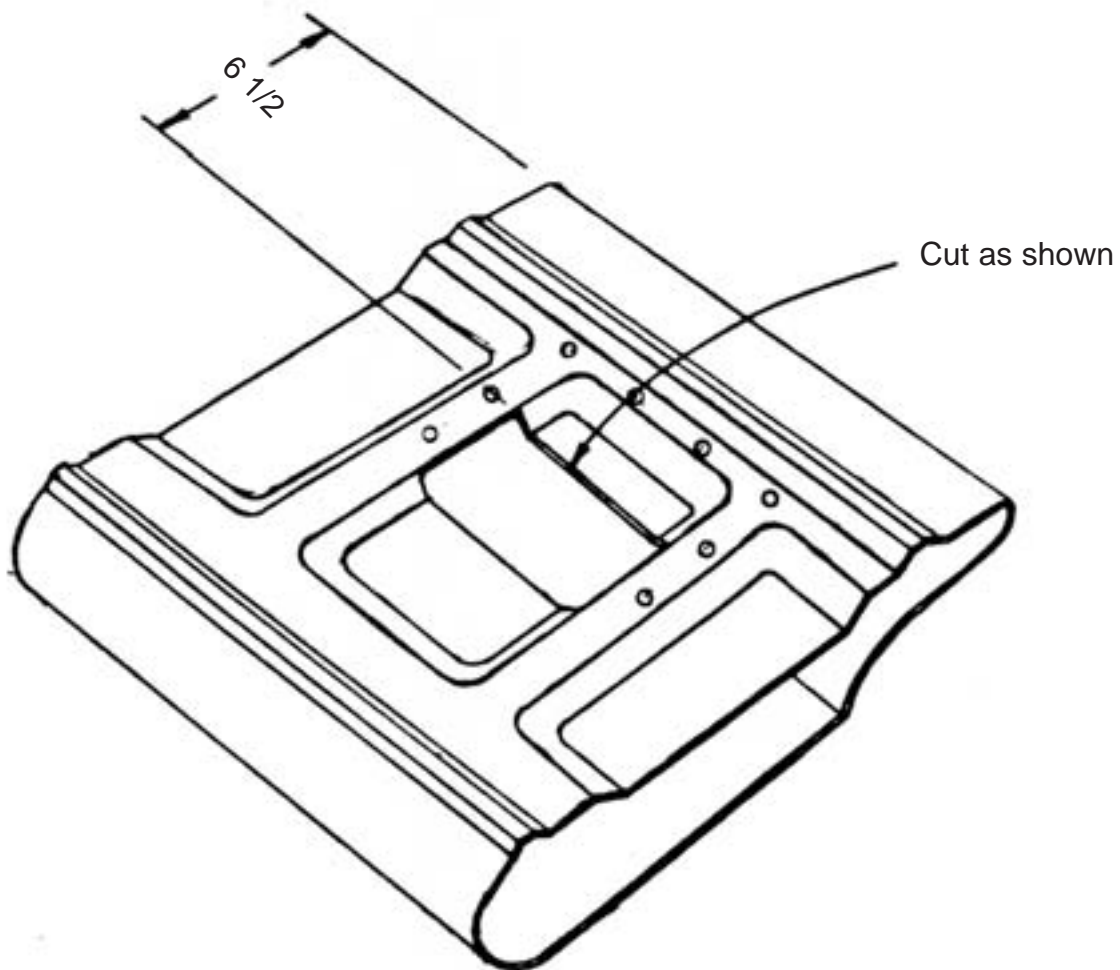
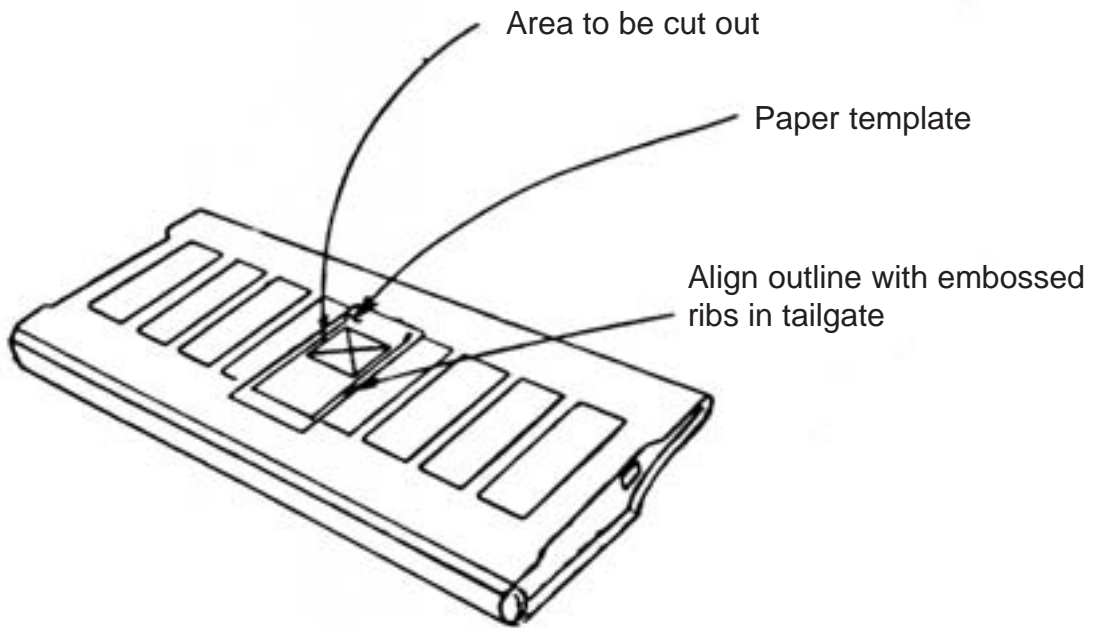

**81-87 Chevy/GMC - Template for Cutout on Tailgate**

