

REAR PANS WITH A LICENSE TAG BOX 67-72 FLEETSIDE AND 73-87 FLEETSIDE

The rear pan fits between the bed sides below the tailgate. It is formed to match the curve of the bed sides so that when installed it fills the open area under the tailgate by carrying the original body lines across the rear of the box.

Suggested Installation Instructions for "bolt - on" applications

1. Remove the bumper and brackets.
2. If installing a pan with a license box, on a 67-72 or 73-87 Fleetside, part of the rear sill will have to be cut away to clear the license box. Cut away an area 14" wide X 1" high (67-72) or 1 3/4" high (73-87) in the lower center of the rear sill (the sheet metal surface below the tailgate).

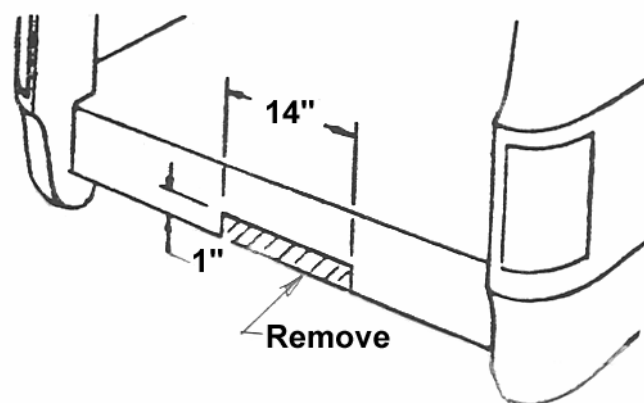

Hold the rear pan in position to make sure it fits. Mark the location on the bedside where the lower edge of the rear pan meets the bedside. This mark will be a reference point for installing the clips which hold the lower edge of the rear pan.

3. If necessary, grind the ends slightly so that the pan fits between the bed sides and is even with the surface of the bed side below the tailgate.
4. Make sure the tailgate will open without binding against the pan and adjust the position as necessary. The tailgate may need to be adjusted, especially if the trunnions are worn or if a tailgate cover is being used. While holding the pan in its proper mounting position, mark the rear sill through the holes along the mounting flange of the rear pan. These marks will be used to locate and drill holes for attaching the pan.
5. Install the clips which hold the lower edge of the rear pan as follows. The clips connect the lower edge of the rear pan to the bedside. Holes must be drilled in the bedside and the rear pan at the time of installation
6. First attach the clip to the bedside. It should be about 3/4" rearward from the reference mark made in step #2 above. Drill a 3/16" hole through the bedside sheet metal 3/8" outward from the turned up inner edge of the bedside.
7. Attach the clips so the center part of each clip straddles the turned up edge of the bedside. Use one of the sheet metal screws provided for each clip. A drop of oil on the screw thread will aid in forming the thread in the clip. The clips should extend into the open area below the tailgate.

8. Centerpunch and Drill for each of the screw holes as marked in step #4 above. Use a 5/32" drill.
9. Temporarily screw the pan to the rear sill using only the two outer screws.
10. Mark the rear pan for the screw holes at the clips on the lower edge. Remove the pan and drill the two holes at 1/4".
11. Again temporarily mount the pan on the bed and verify that all holes are aligned and that the tailgate will open without binding.
12. Remove the pan from the truck and paint to match the truck. The back side of the pan should also be painted to provide rust protection.
13. Before installing the pan, screw one of the sheet metal screws in and out of each drilled hole to properly form the threads. This makes it much easier when attaching the pan.

Suggested Installation Instructions for "Weld- on" applications

1. Remove the bumper and brackets.
2. If installing a pan with a license box, on a 67-72 or 73-87 Fleetside, part of the rear sill will have to be cut away to clear the license box. Cut away an area 14" wide a 1" high in the lower center of the rear sill (the sheet metal surface below the tailgate). Hold the rear pan in position to make sure it fits.
3. If necessary, grind the ends slightly so that the pan fits between the bed sides and is even with the finished surface of the bed side below the tailgate.
4. **Make sure the tailgate will open without binding against the pan and adjust the position if necessary. The tailgate may need to be adjusted, especially if the trunnions are worn or if a tailgate cover is being used.** The tailgate must be in place and properly adjusted before continuing with step 5. '72 or earlier tailgate cannot be removed after the pan is installed. After the pan is installed the tailgate trunnions are difficult to adjust.
5. Tack weld the pan to the bed sides a couple of places on each end. Check the edges of the pan for proper alignment to the bed sides. Also check that the gap between the tailgate and the pan is uniform width from one side to the other. When the alignment is satisfactory, permanently weld the pan to the bedside at each end.
6. Weld or screw the pan to the rear sill of the bed floor below the tailgate. Minor shims or spacers may be required so the tailgate will still open without binding.
7. Fill the welded seam at the bed sides with bondo or lead. Grind the seam to the body contour.
8. The pan is now ready for paint finishing.

©Copyright 1997 MAR-K Specialized Mfg. All rights reserved.

Another Outstanding Part Manufactured in Oklahoma City, USA by

