

REAR PANS 58-59 FLEETSIDE

The rear pan fits between the bed sides below the tailgate. It is formed to match the curve of the bed sides so that when installed it fills the open area under the tailgate by carrying the original body lines across the rear of the box.

Installation Instructions (THIS IS ONLY A SUGGESTION)

1. Remove the bumper and brackets.

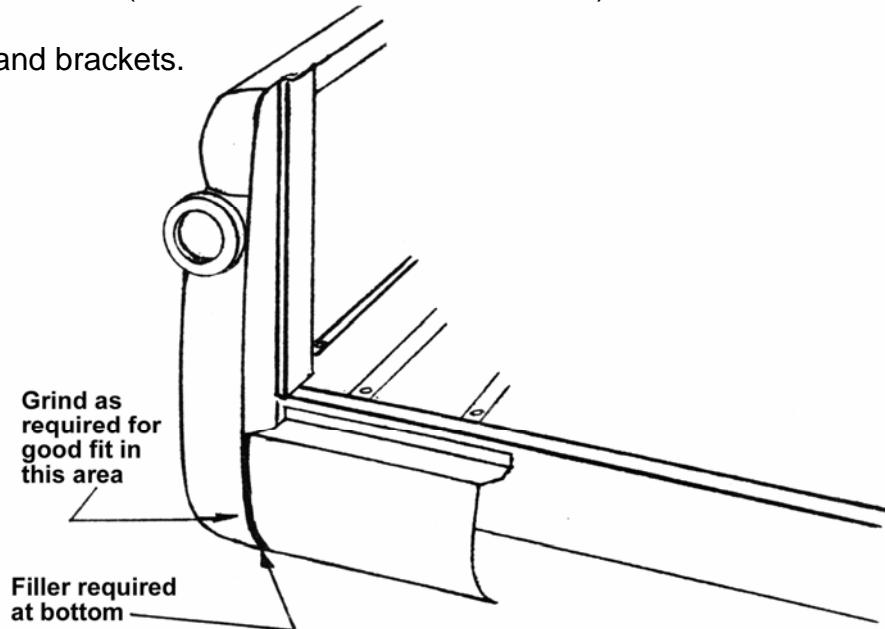

2. Hold the rear pan in position to make sure it fits.
3. If necessary, grind the ends slightly so that the pan fits between the bed sides and is even with the finished surface of the bed side below the tailgate.

CAUTION: After the pan is installed, the tailgate must always be supported by the chains when opened. Allowing the tailgate to drop without support may damage the pan or tailgate.

4. Tack weld the pan to the bed sides a couple of places on each end. Check the edges of the pan for proper alignment to the bed sides. Also check that the gap between the tailgate and the pan is uniform width from one side to the other. When the alignment is satisfactory, permanently weld the pan to the bedside at each end.
5. Weld or screw the pan to the rear sill of the bed floor below the tailgate. Minor shims or spacers may be required so the tailgate will still open without binding.
6. Fill the welded seam at the bed sides with bondo or lead. Grind the seam to the body contour.
7. The pan is now ready for paint finishing.

©Copyright 1997 MAR-K Specialized Mfg. All rights reserved.

Another Outstanding Part Manufactured in Oklahoma City, USA by



RESTORATION & CUSTOM PICKUP PARTS

BED STRIPS

BED WOOD

- Bed Sides
- Tailgates
- Cross Sills
- Rear Sills
- Hardware
- Front Bed Panels

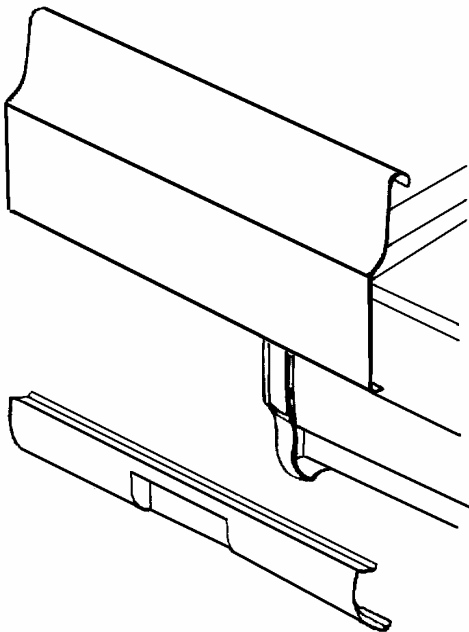
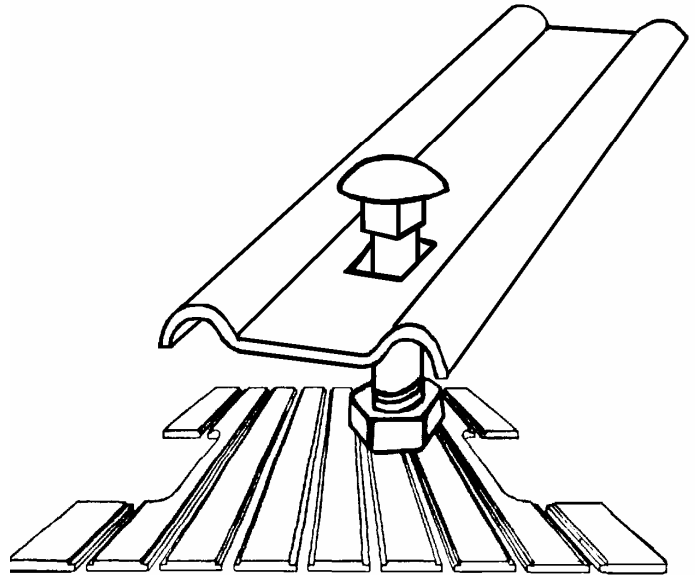

REAR PANS FRONT PANS TAILGATE COVERS HANDLE KITS

- Weld on or bolt on panels
- Complete instructions included
- 18 Gage steel
- Smooth or Louvres

**** PARTS AVAILABLE VARY EACH STYLE – CALL FOR MORE INFO****