

REAR PANS WITH OR WITHOUT A LICENSE TAG BOX 73-UP FORD STYLESIDE

The rear pan fits between the bedsides below the tailgate. It is formed to match the curve of the bed sides so that when installed it fills the open area under the tailgate by carrying the original body lines across the rear of the box

Installation instructions.

1. Remove the bumper and brackets.
2. Hold the pan in position to make sure it fits. The tailgate should open without binding against the pan. Adjust the position of the tailgate or rear pan if necessary.
3. While holding the pan in the mounting position, carefully mark the location of the outer screw holes to be drilled in the rear sill below the tailgate. Be sure the gap between the tailgate and pan is of uniform width from one side to the other.
4. Remove the tailgate and rear pan. Centerpunch and drill for the two screw holes as marked in step #3 above. Use a 5/32" drill.
5. Temporarily install the rear pan using the two outer screw holes drilled in step #4 above. Replace the tailgate to verify the pan is properly positioned before permanently mounting it to the truck. Mark the locations of all the other mounting holes along the top and at the two clips on the lower edge of the pan.
6. Remove the tailgate and rear pan. Centerpunch and drill for all remaining screw holes using a 5/32" drill. Use care to prevent the drill point from damaging the outer fender surface when the drill breaks through the holes for the clip on the lower edge of the pan.
7. The pan may now be paint finished to match the truck. The back side of the pan should also be painted to protect from rust.
8. Before installing the pan, screw a sheet metal screw in and out of each drilled hole to properly form the threads. Use a drop of oil to aid in forming the threads.
9. Install the pan and tailgate

©Copyright 1997 MAR-K Specialized Mfg. All rights reserved.

Another Outstanding Part Manufactured in Oklahoma City, USA by



RESTORATION & CUSTOM PICKUP PARTS

BED STRIPS

BED WOOD

- Bed Sides
- Tailgates
- Cross Sills
- Rear Sills
- Hardware
- Front Bed Panels

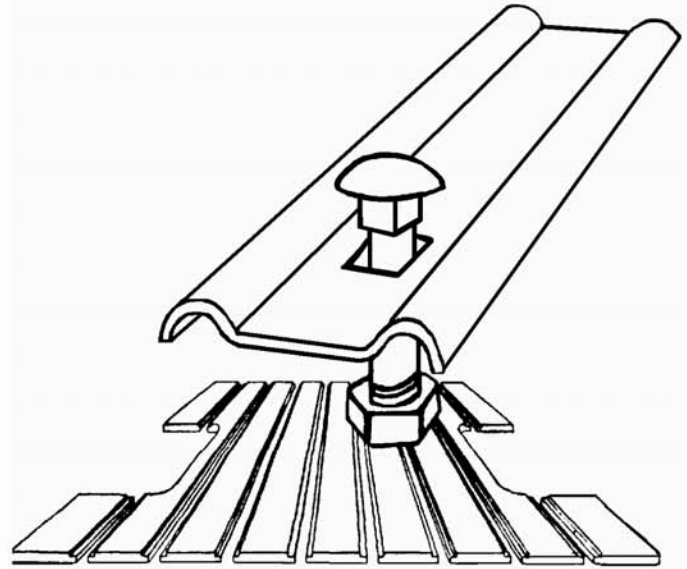

REAR PANS

FRONT PANS

TAILGATE COVERS

HANDLE KITS

- Weld on or bolt on panels
- Complete instructions included
- 18 Gage steel
- Smooth or Louvres

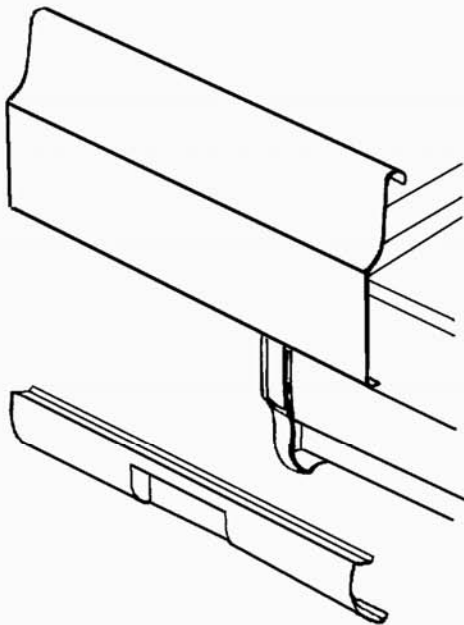

****PARTS AVAILABLE VARY FOR EACH STYLE – CALL FOR MORE INFO****