

1953-1956 FORD FLARESIDE FULL HEIGHT REAR PANS

The rear pan fits between the bedsides below the tailgate. It is curved and fills the open area under the tailgate when the bumper is removed.

Installation Instructions (THIS IS ONLY A SUGGESTION)

1. Remove the bumper and it's mounting brackets.
2. The top of the rear pan is designed to fit flat against the rear cross sill and slip underneath the rear wood sill protector. Temporarily clamp the rear pan end panels under the lower rear flanges of the bedsides and to the lower fender area so that the pan fits in position between the bedsides and fenders.
3. Weld or screw the rear pan to the rear lower bedside flanges.
4. You may also wish to bolt or screw the rear pan end panels to the lower part of the rear fenders. This will keep the rear pan from rattling against them.
5. We suggest that you weld the upper portion of the pan to the rear cross sill next to the stake pockets. There will be approximately a 3/16" gap between the stake pockets and the rear pan on each side. Tack weld the rear pan and stake pockets to the rear cross sill and then fill in this area with body filler.
6. The pan is now ready for painting.

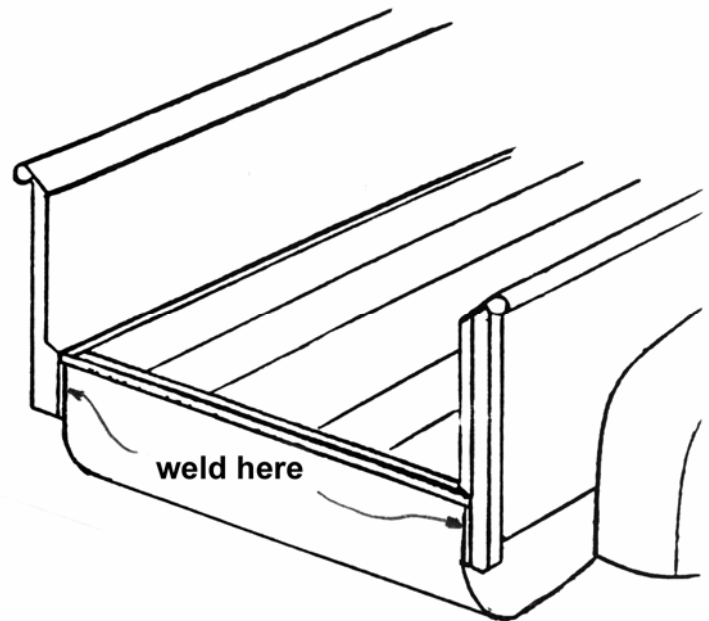
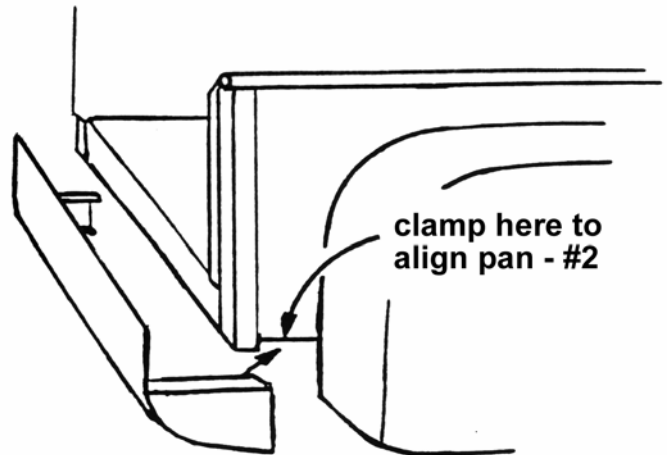

©Copyright 1997 MAR-K Specialized Mfg. All rights reserved.

Another Outstanding Part Manufactured in Oklahoma City, USA by

MAR-K
RESTORATION AND CUSTOM PICKUP PARTS

RESTORATION & CUSTOM PICKUP PARTS

BED STRIPS

BED WOOD

- Bed Sides
- Tailgates
- Cross Sills
- Rear Sills
- Hardware
- Front Bed Panels

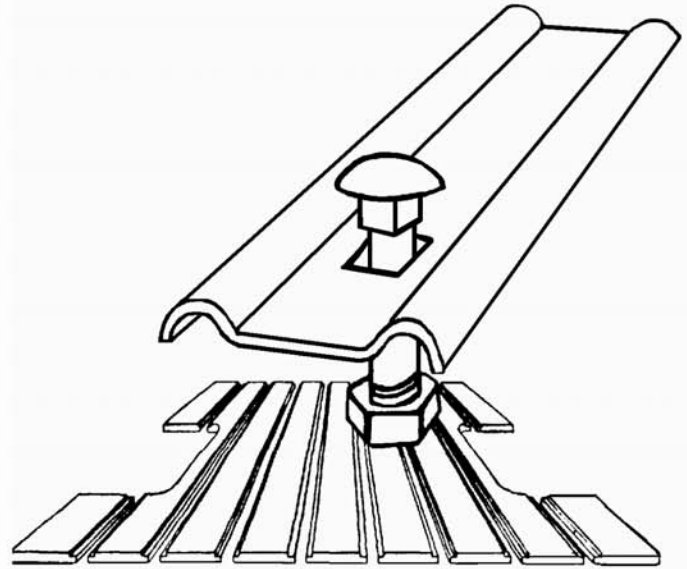

REAR PANS

FRONT PANS

TAILGATE COVERS

HANDLE KITS

- Weld on or bolt on panels
- Complete instructions included
- 18 Gage steel
- Smooth or Louvres

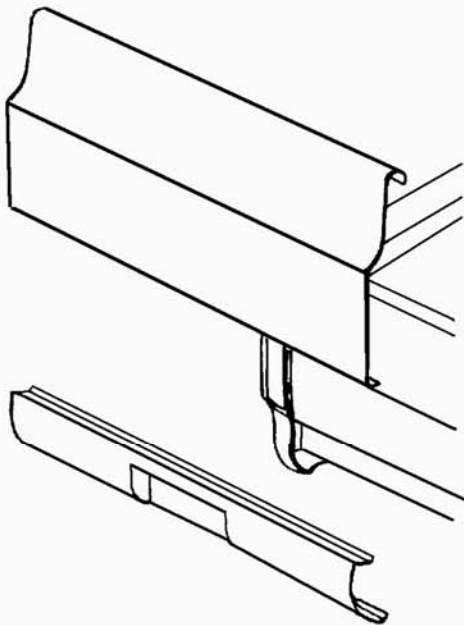

****PARTS AVAILABLE VARY FOR EACH STYLE – CALL FOR MORE INFO****