

## **FORD 53-87 FLARESIDE TAILGATE FULL COVER** **INSTALLATION SUGGESTIONS**

1. Remove original tailgate from the truck.
2. Straighten the tailgate if it is bent or twisted. If installing a louvered cover, paint the rear face of the tailgate with a flat black paint to prevent the original paint from showing through the louvres.
3. The chain latch brackets at the top of the tailgate will have to be removed to install the tailgate cover. If you plan to remove the brackets permanently and use another method to hold the tailgate closed, simply saw them off and grind the tailgate smooth and proceed to step 5 below. If you plan to keep the chain latches and hooks to close the tailgate, the brackets will be sawed off to install the tailgate cover and then welded back on in the original location. Before sawing off the brackets make some measurements for reference use when welding them back in the same place. Record the measurements between the brackets, the distance down from the top of the tailgate to the brackets, and the length they extend out from the tailgate. Keep these measurements for use in welding the brackets back on the tailgate. Saw the brackets off close to the tailgate skin and grind the original welds smooth so that the cover will install tight against the original tailgate skin contour.
4. The tailgate cover needs to have a slot at each end where the latch brackets will be welded back in position. Temporarily install the cover on the tailgate and mark the location on the cover where the latch brackets will extend through the cover. Saw a slot through the cover about 5/8" wide for clearance around the latch bracket. A jig saw with a fine tooth blade or a nibbling tool may be used for this cut. Be careful not to distort the sheet metal.
5. Place the cover on the tailgate at the top first, then push the bottom over the bottom of the tailgate. It may be necessary to push downward on the cover to permit the bottom of the cover to seat properly. The cover fits tight against the lower area of the tailgate ends and with a slight gap in the center area between the end pieces. At this point check that the slots which were cut in step 4 above will permit the latch brackets to be welded back on in the original locations. Enlarge the slots at this time if required.
6. Weld the tailgate cover onto the tailgate. Weld the bottom to the end pieces where the fit is tight, leaving the center area unwelded to permit moisture to drain out. Weld the top edge with a series of tack welds 2 inches apart, keeping weld heat at a minimum to prevent distortion.
7. Weld the latch brackets back on in their original locations. Tack weld first to verify the measurements taken in step 3 above. Be sure that the welds penetrate to the original latch bracket under the cover and are not just welded to the sheet metal skin.
8. Grind the welds and fill the top seam if desired with body putty or lead solder to properly finish the seam before painting. Do not fill the bottom seam.
9. Prepare and paint the tailgate as the rest of the box.
10. When installed, the tailgate should not be lowered fully down as the extra metal thickness of the cover may rub against the rear of the bed.

©Copyright 1997 MAR-K Specialized Mfg. All rights reserved.

# RESTORATION & CUSTOM PICKUP PARTS

## BED STRIPS

## BED WOOD

- Bed Sides
- Tailgates
- Cross Sills
- Rear Sills
- Hardware
- Front Bed Panels

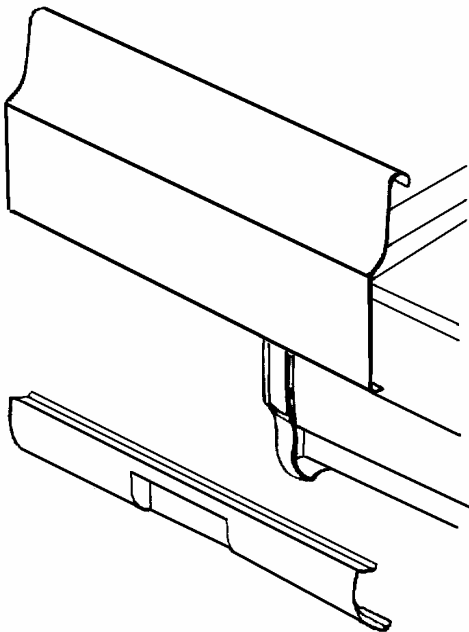
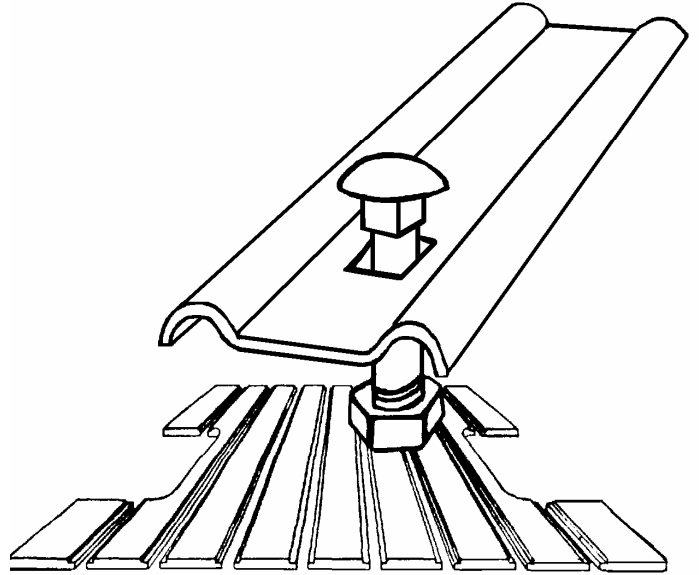

## REAR PANS FRONT PANS TAILGATE COVERS HANDLE KITS

- Weld on or bolt on panels
- Complete instructions included
- 18 Gage steel
- Smooth or Louvres

**\*\* PARTS AVAILABLE VARY EACH STYLE – CALL FOR MORE INFO\*\***