

# ANGLE STRIP COVER

- Cover fits over the existing Angle Strip.
- Holes to be drilled at the time of installation.

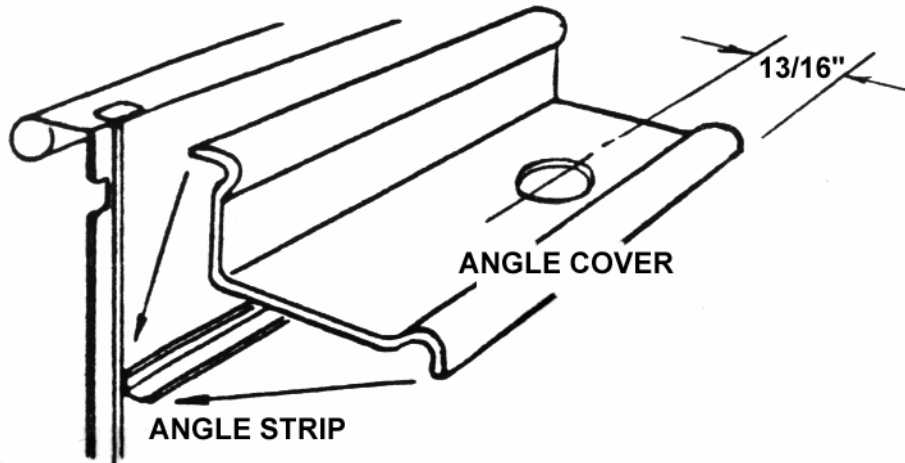

1. Take the bolts out of the old angle strip-straighten any bent or damaged areas.
2. Lay the new angle cover over the old angle and clamp it in place where you want it.
3. From the underside of the original angle strip, mark the angle cover hole location, marking through the original angle strip holes.
4. Remove the cover & drill the holes in the angle cover to  $21/64$  diameter for "rib neck" bolts or  $13/32$  diameter for standard carriage bolts. They must be drilled  $13/16$ " from the rolled edge of the angle cover and aligned with the bolt holes in the original angle.
5. Remove any heavy burr from the top surface of the drilled hole.
6. Place the angle cover back on the original angle and verify that all holes align properly. Put a bolt,  $5/16$ - $18 \times 1-1/2$ " long, in each hole. If using a standard carriage bolt rotate it so that the square shoulder of the carriage bolt aligns with the square hole in the original angle. Note that the square shoulder of the carriage bolt is slightly larger than the drilled hole. This allows the corners of the square shoulder to dig in to the edge of the hole and prevent the bolt from spinning when the nut is tightened.
7. Start a nut and washer on each bolt. You may need to have 2 people-one to hold the bolt and another under the truck to tighten the nut. When all nuts are started, tighten all of them starting from the center of the strip and working toward the ends. Tighten just enough to draw the head down tight against the angle cover surface.