

MAR-K

RESTORATION AND CUSTOM PICKUP PARTS

BED PARTS ASSEMBLY GUIDE 1937-39 CHEVY SHORT STEPSIDE

If you have not yet disassembled your original bed, make notes or sketches and take pictures of part locations to aid in the assembly procedure. Use the following steps to assemble the entire bed to test fit all parts.

1. Begin with one bed side and the front bed panel. Bolt the front bed panel flange to the inside of the bed side with (4) 1/4"-20 x 5/8" hex head bolts, lock washers, and nuts from the front bed panel mounting bolt kit. See figure 1.
2. This bed also uses a long rod that attaches through the front bed panel curl to the bed sides. Install a 5/16" flat washer, lock washer, and nut on one end of the rod. Insert the rod through the top hole in bed side into the top curl of the front bed panel.
3. Align and install the loose end of the rod through the other bed side and secure with a 5/16" flat washer, lock washer, and nut. See figure 2.
4. Bolt the front bed panel to the other bed side with (4) 1/4"-20 x 5/8" hex bolts, lock washers, and nuts.
5. Fit the rear cross sill inside the lower portion of the bed side rear stake pockets with the open side of the rear cross sill facing downward. See figures 3 and 4. The flanged side of the sill faces toward the front bed panel.
6. Using (8) 5/16"-18 x 3/4" indented hex head bolts, nuts, and lock washers, bolt the rear cross sill to the stake pockets. Use the bottom (4) holes in each rear stake pocket only for now.
7. Once these four pieces of the bed are assembled, you will need to make sure your bed is square. Measure the bed width at the top and bottom of bed sides to ensure that the bed sides are straight up and down and are 45-3/4" apart. See figure 5. Now tighten the rear cross sill bolts.

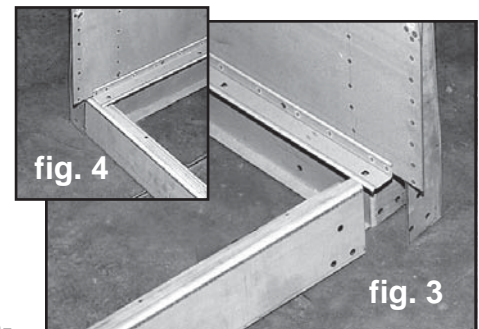
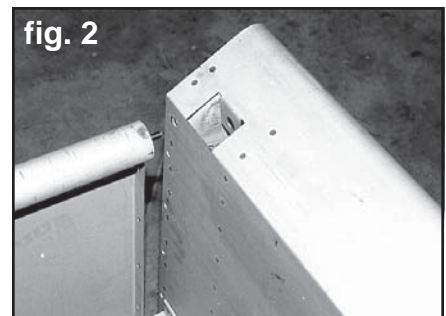
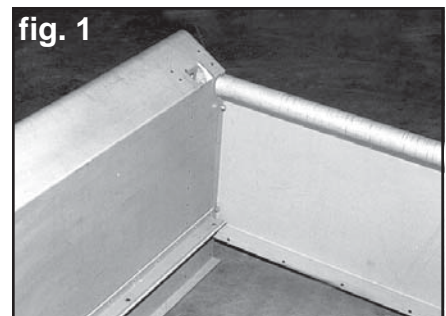

8. Measure crosswise from the front of the bed to opposite rear on both sides. These measurements should be within 1/16" of each other to ensure that the bed is square. Now tighten all bolts. See figure 6.
9. Place the assembly on supports horizontally to gain access to both the top and bottom of the bed floor area. See figure 7. This can also be achieved by standing the bed assembly vertical. Place a blanket or other suitable protection on the floor and stand the bed assembly on the front bed panel.
10. Place the wood boards that have only one bed strip groove (referred to as "edge boards") under the angle strips on the bed sides. The non-grooved edge should be toward the bed side. Leave approximately a 1/16" inch gap between the bed side and the board. See figure 8.
11. Mark all holes to be drilled in the edge boards through the angle strips holes. See figure 8. Note that there are two holes near the rear end of the angle that are 3/8" square. These will be drilled 1/2" for the bed-to-frame bolts.
12. The front of the edge board rests on top of the front panel lower flange. This flange bolts directly to the edge boards. Mark these holes through the holes in the front panel onto the bottom of these two edge boards. These holes should fall close to the middle of each board, approximately **5-3/8"** from each bed side.
13. Remove these two edge boards and drill the holes marked using a 3/8" wood bit. Drill the two holes that were marked through the 3/8" square holes in the angle near the rear with a 1/2" wood bit. Be careful not to splinter the other side of the board when drilling. Placing a wood block behind the board where drilling will help prevent this. See figure 9.
14. Install the edge boards underneath the angle strips as in step #10. Place 5/16"-18 x 1-1/2" carriage bolts through the angle strips and the boards skipping the holes that were drilled 1/2". See figure 10. Also install these through the boards and the front bed panel lower flange. Leave off the lock washers and nuts for now.

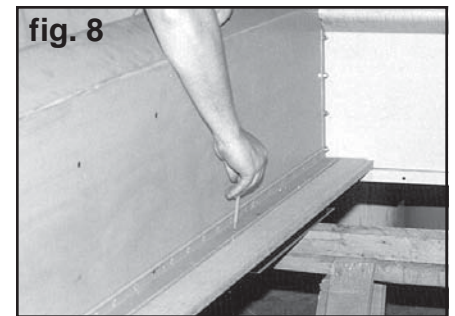
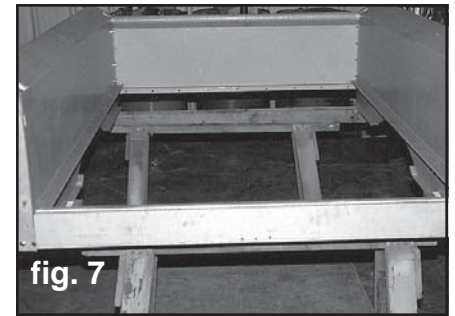
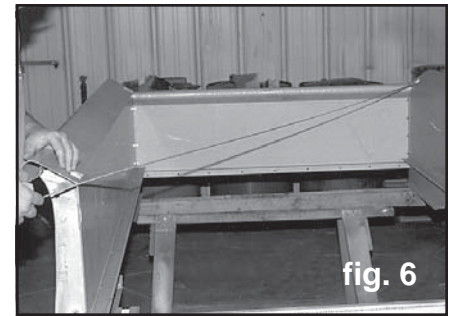

15. Attach a cross sill to the 5/16" bolts in the angle strips at approximately **2-3/4"** from the front bed panel. Install lock washer and nut and hand tighten. The cross sill should be installed so that when the bed is installed on the frame the cross sill should be open toward the ground. See figure 11.

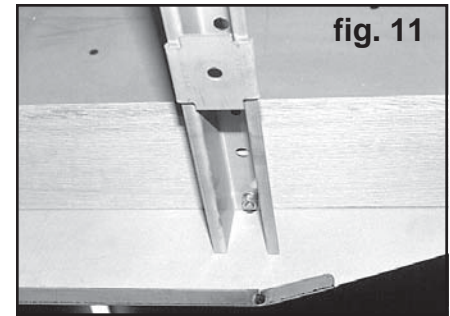

Note: The next step is to drill and countersink the locations for the bed-to-frame bolts and offset washers that sit on the top of the wood surface. If wood was purchased with the holes predrilled, skip to step #21. If wood was purchased without holes, the following steps will direct you through this process.

16. The first cross sill closest to the front bed panel is the first bed-to-frame hole location. Mark the bottom of both edge boards through the 1/2" diameter cross sill holes that are **36-1/2"** apart from center of hole to center of hole. See figure 12.



17. Make reference as to which end of each edge board is at the front of the bed. Remove the cross sill and boards. The bottom side of these boards should now have a 1/2" hole marked on each of them. Drill a 1/8" diameter pilot hole through the center of these marks completely through the boards.

18. On the top surface of the boards, measure toward the front of each board 3/16" from the front pilot holes and mark the boards for the countersunk bed-to-frame offset washer. See figure 13.

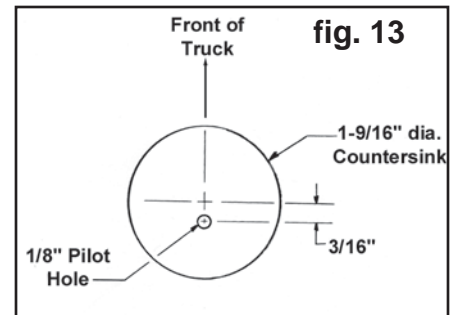

19. Using a 1-9/16" diameter Forstner bit, a drill press if available, or a hand drill, countersink each location approximately 1/8" to 5/32" deep. See figure 14.

20. From the top surface, drill through the 1/8" pilot holes with a 1/2" drill bit to complete the bed-to-frame holes. See figure 15.
21. Reinstall the edge boards. Before re-installing the front cross sill, slide a pair of the center-hole cross sill brackets on the cross sill. The second cross sill is installed at **26-5/8"** from the front panel. It does not require cross sill brackets because it does not rest on the frame. The third cross sill attaches to the angles at **53"** from the front bed panel and gets the offset hole brackets with the hole offset toward the outside of the bed. You will need to use a 3/8" carriage bolt to attach the third cross sill to the angles. All brackets should line up with the bed-to-frame holes in the cross sills and wood.
22. Make sure that the bed-to-frame hole spacing measurements are the same as listed in step #16 for the front cross sill. The rear spacing is controlled by the width of the bed.
23. Where there is not a cross sill attached to the angle strip bolts, install a 1-1/2" outside diameter flat washer with a 5/16" diameter hole on the bottom of the wood surface before installing lock washer and nut hand tight. See figure 16.
24. Install a 5/16" flat washer, lock washer, and nut to the front bed panel bolt attached to the edge board hand tight.

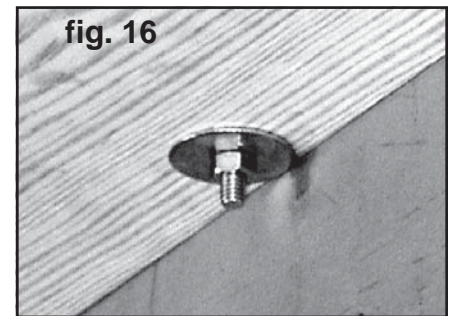
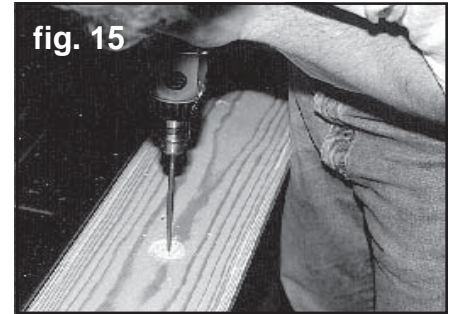

25. Place the next board into position on both sides leaving approximately a 1/2" space between the boards. Place a bed strip in the grooves on top of the boards. The end of the strip with the hole closest to the end is positioned on the rear cross sill. See figure 17. The bed strip holes should line up to each cross sill. Loosely install the 1/4" bed strip bolts, nuts, and lock washers. *If using MAR-K's custom bed strips with hidden fasteners, follow the instructions supplied with those bed strips for correct installation.*



26. Where there is not a cross sill under the bed strip bolt, install a 1-1/2" outside diameter washer with a 1/4" diameter hole before installing lock washer and nut. See figure 18.

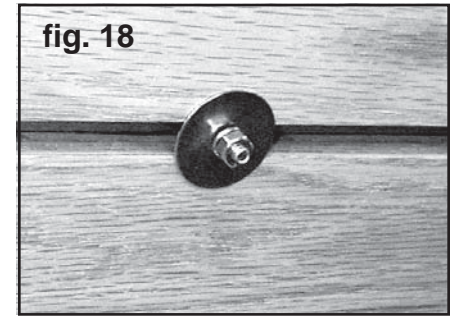

27. Continue installing boards and strips from both sides working toward the center. Adjust the gaps between the bed strips and the boards before tightening the bolts. Do not over tighten or broken bolts and damaged bed strips may occur.

28. Mark the front of the remaining boards through the front bed panel lower flange as in step #12 after the spacing of the strips and the wood is satisfactory. These holes will be drilled 3/8" diameter prior to wood finishing.

29. Install the completed bed assembly to the truck frame. You will need to remove the 3/8" carriage bolt from the #3 cross sill where it is attached at the angle strip. This will enable you to check the alignment of the bed-to-frame bolt locations. The order in which parts are installed on the truck frame is: rubber pad, wood mounting block, cross sill bracket/cross sill, and the bed assembly. See figure 19. Make sure that the wood blocks with the offset hole are located under the third cross sill that has the offset hole cross sill brackets attached. At this time you need to install the large wood blocks at the rear of the bed. These large wood blocks fit up against the bottom of the edge boards and rest on the rubber pad on top of the frame. The notched cut on the bottom of the wood block should be against the bottom of the bed side. The rear most bed-to-frame bolt can now be installed. These bolts hold the bed-to-frame blocks in place. The large washers shown under the bolt heads are omitted on 37-39 Chevy short beds for the rear.

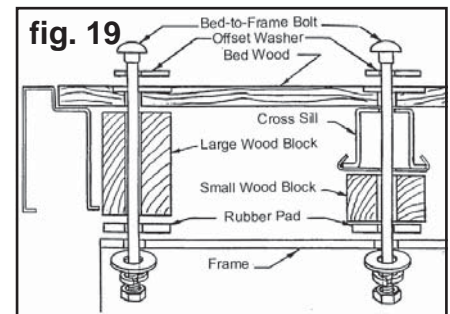

30. After checking the alignment of the bed assembly to the cab and frame mounting holes, install the (6) 3/8-16 X 6" bed-to-frame bolts and (2) offset washers on the top of the wood. Remember the rear (4) bed-to-frame bolts go through the angle strip and will not need a washer on the top. Install the flat washers, lock washers, and nuts on the bottom side.
31. Install one hinge onto passenger side rear stake pocket with (2) 5/16"-18 x 3/4" indented hex bolts. Install the tailgate onto this hinge. Install the second hinge into the other end of the tailgate. Bolt the second hinge to the driver side stake pocket. See figure 20.
32. Install the tailgate chain closeable links onto the stake pockets brackets. See figure 21, 22 and 23. Do not squeeze the closeable links shut with pliers yet. Leave them open until final assembly. This model has a left and right tailgate chain assembly. Install the chains so that the hook end does not point at the tailgate when latched or holding the tailgate open. Check the tailgate for proper operation.
33. You have assembled the entire bed. Check all parts for correct fit and alignment. Be sure the bolts are in place and that all dimensions are correct. Now remove the bed from the frame and disassemble the parts to prepare for painting.

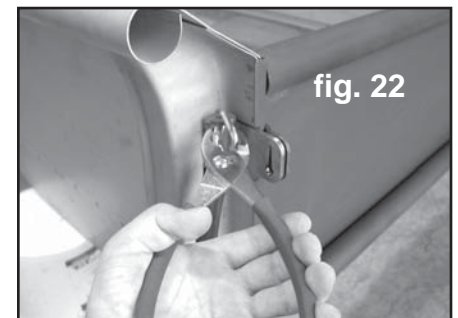
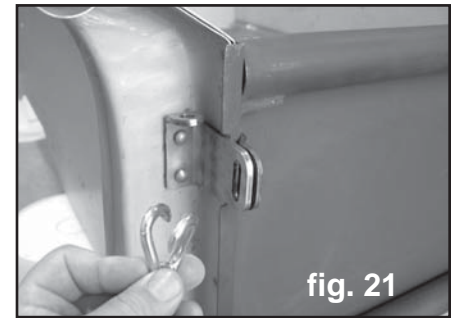
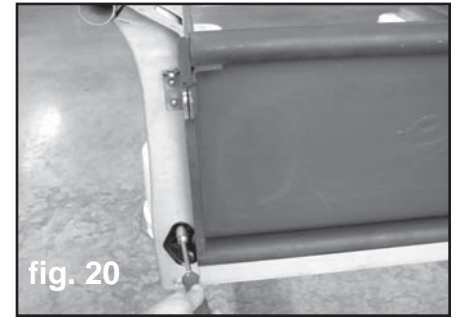

FINAL ASSEMBLY

After the parts are painted, the bed is assembled by the same procedure. By taking the time to assemble and test fit the bed before painting, you have reduced the chances for errors or problems in final assembly.



FACTS ABOUT OUR PARTS

Stainless Steel: Bed strips, angle strips, and stainless mouldings are made of type 430 or 434 bright stainless steel, selected because of its color. It is a magnetic grade of stainless formulated for automotive stainless steel trim. When it is polished and buffed, its bright color looks similar to chrome plating. Stainless hardware items such as bolts, nuts, tailgate chain parts, and bed-to-frame washers are made of nonmagnetic stainless selected for superior resistance to rust and corrosion.

Care of Stainless / Rusting: With proper care, stainless steel will remain bright and smooth for long periods of time. It may be cleaned with liquid polish intended for stainless or chrome. DO NOT use steel wool, a steel wire brush, or a buffing wheel which has been used on steel or other metals. Bright stainless parts should be coated with a good nonabrasive wax for maximum protection. Stainless steel will rust or corrode under certain conditions, especially when contaminants such as salt water, battery acid, or steel particles and moisture are present. Frequent washing and waxing are a great protection against damage to stainless steel surfaces.

Electro-galvanized Steel: Many of the sheet metal parts MAR-K manufactures are made of electro-galvanized steel. This means the metal is electroplated with a thin layer of zinc by the steel manufacturer. There are several reasons for selecting this steel for our product.

1. Electro-galvanized steel is clean and dry.
2. The zinc protects our parts from rusting during our processing and while on the shelf.
3. After the parts are painted, the zinc under the paint helps prevent loss of paint adhesion or rusting if the paint surface is scratched or damaged.

Preparing Parts for Painting: The objectives of painting a part are to protect the metal and to provide a beautiful colored surface. No matter how beautiful the paint, if it doesn't stick to the surface, it will not be satisfactory. Excellent paint adhesion to a metal surface depends mainly on two things, the quality and characteristics of the primer used, and how well the surface is cleaned and prepared for painting. Prepare the surface as follows to help the paint have the best adhesion possible.

Steps for Excellent Paint Adhesion on MAR-K parts

The following steps are a general guideline to obtain excellent paint adhesion to your new parts

1. Select the primer product with the best adhesion properties within the paint system you are using. Products such as PPG "DPLF Epoxy Primer", Sherwin Williams G.B.P. Etching Filler or Etching Primer, and DuPont Variprime 615S/625S Self-Etching Primer will provide excellent adhesion to MAR-K metal parts that have been properly prepared for painting.

2. Wipe the part with solvent such as PPG DX330 Wax and Grease Remover, Sherwin Williams R7K156 Solvent Cleaner, or DuPont 3919S Prep-Sol to remove grease and lubricants from the manufacturing process.
3. Scrub all surfaces of the part with mild detergent in hot water. Rinse well and wipe dry with a clean dry cloth.
4. Wipe the part again with solvent as in step 2 above. The surface must be absolutely clean before sanding to prevent the sanding process from spreading the contaminants or imbedding them into the surface.
5. Scuff sand all areas to be painted using progressively finer grit to about 240 grit paper. Do not try to completely remove or sand through the zinc plating, but the complete part must be thoroughly sanded for best paint adhesion. Use a "DA" sander for broad flat areas and hand sanding for areas that can't be reached with the power sander.
6. Wash and rinse away all sanding residue. Use compressed air to blow the rinse water out of all seams and dry the parts with a clean towel. If the rinse water beads up anywhere on the surface, it is not clean and the solvent wipe and water washing steps must be repeated and additional sanding may be required in that area.
7. Wipe with solvent such as PPG DX330, Sherwin Williams R7K158, or DuPont 3901S to remove any traces of contaminants or sanding residue. Wipe the surface dry with a clean cloth. Do not allow the solvent to evaporate dry on the surface. Wet it again if it should evaporate dry.
8. The parts should be ready for prime painting. PPG recommends a final wipe with a clean damp cloth to remove any residue left from evaporation of the solvent. A quick wipe with a tack rag right before priming helps remove any remaining dust.
9. Immediately after cleaning and drying the parts as above, apply the primer according to the manufacturer's instructions for the products you are using. The recommended drying time between coats is especially important.

Some other helpful hints for a successful paint job.

1. Be sure to use fresh paint products that are top quality from a reputable manufacturer. Do not try to economize by using inferior or leftover paint materials.
2. Select all the products for a paint job from a single manufacturer and do not mix different systems within a brand of paint. Use only products that are intended to be used together.
3. Do not use the same air hoses on your paint gun that are also used with air tools such as sanders and air wrenches. Oil in the air tools will find its way into the hose and be a source of contamination for the paint. New hoses contain oils and other contaminants and should be cleaned before use on a paint gun.
4. Wear clean latex or nitrile gloves to prevent fingerprint oils from contaminating the surfaces of your cleaned parts.
5. Plan to prime the parts immediately after cleaning and sanding to prevent any bare steel areas from developing surface rust or the parts from becoming contaminated again.
6. Obtain a technical data sheet for each product being used and read and follow the instructions. The manufacturer's data sheet will provide specific instructions that apply to the product being used. These are available on-line or from your paint supplier.

©Copyright 2007 MAR-K Quality Parts L.L.C. All rights reserved.