

MAR—K

RESTORATION AND CUSTOM PICKUP PARTS

BED PARTS ASSEMBLY GUIDE 51-52 FORD SHORT FLARESIDE

If you have not yet disassembled your original bed, make notes or sketches and take pictures of part locations to aid in the assembly procedure. Use the following steps to assemble the entire bed to test fit all parts.

1. Begin with one bed side and the front bed panel. Bolt the front bed panel's top angled flange to the top side of the bed side with (2) 5/16"-18 x 3/4" indented hex head bolts from the front bed panel mounting bolt kit. See figure 1.
2. Bolt the front bed panel to the other bed side with (2) 5/16"-18 x 3/4" indented hex bolts. The side flanges of the front bed panel should be on the outside of the bed sides. See figure 1.
3. Fit the rear cross sill inside the lower portion of the bed side rear stake pockets with the open side of the rear cross sill facing downward. The side with the brackets on the rear cross sill faces toward the front bed panel. See figure 2.
4. Using (2) 1/4"-20 x 2-3/4" hex head bolts, nuts, and lock washers, bolt the rear cross sill to the stake pockets. Use only the bottom hole locations to attach the rear sill. See figure 3. There should be a gap between the top of the rear cross sill and the lower lip of the bed side. This is where the wood will go.
5. Once these four pieces of the bed are assembled, you will need to make sure your bed is square. Measure the bed width at the top and bottom of straight part of bed sides to ensure that the bed sides are straight up and down and are **49"** apart. See figure 4. Tighten the rear cross sill bolts. Be careful not to overtighten the bolts going through the rear cross sill and stake pocket.

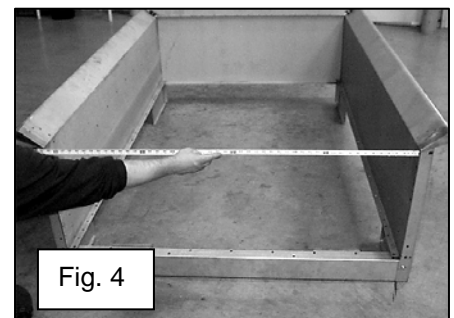
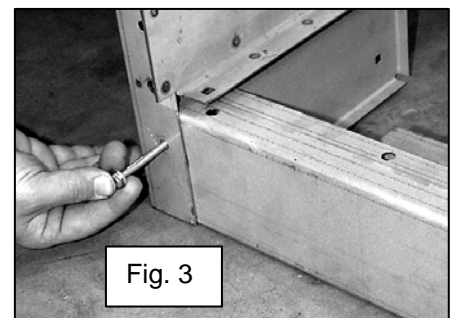
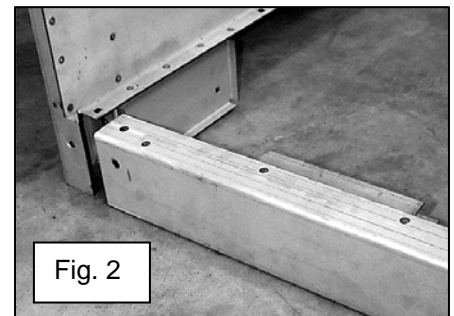
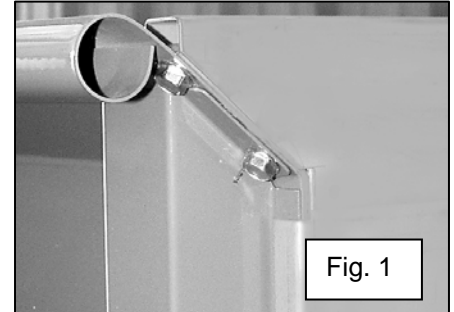

6. Also measure crosswise from the front of the bed to opposite rear of the bed on both sides. See figure 5. These measurements should be within 1/16" of each other to ensure bed squareness.

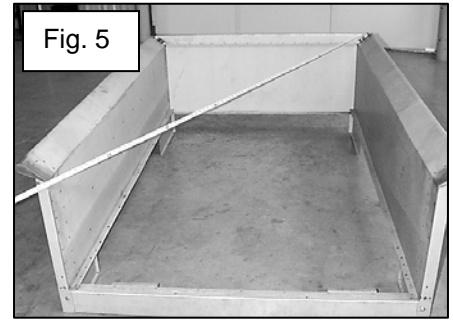

7. Place the assembly on supports horizontally to gain access to both the top and bottom of the bed floor area.

8. Install the edge boards under the lower bed side lip on the left and right hand side. These edge boards are identified by the 1-1/16" wide by 1/16" deep machined recess along the length of the two boards. See figure 6. This recess fits under the bed side lip. See figure 7. These boards have the rear end of the board machined as well for the rear bed wood sill protector. This end fits at the rear cross sill. This means that there is a left and right hand edge board.

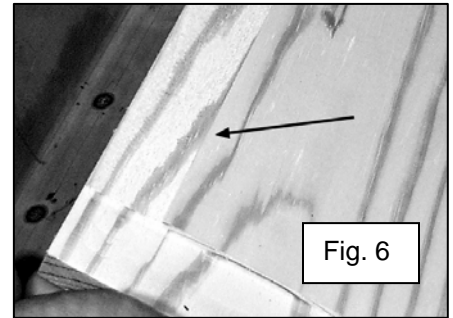

9. Mark all holes to be drilled in the wood boards through the bed side lower lip holes. See figure 8.

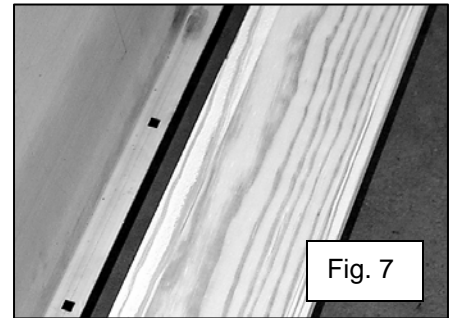

10. Remove these two boards and drill all holes marked using a 3/8" wood bit. See figure 9. Be careful not to splinter the other side of the board when drilling. Placing a wood block behind the board where drilling will help prevent this.

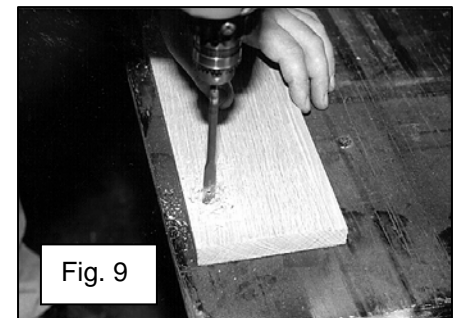
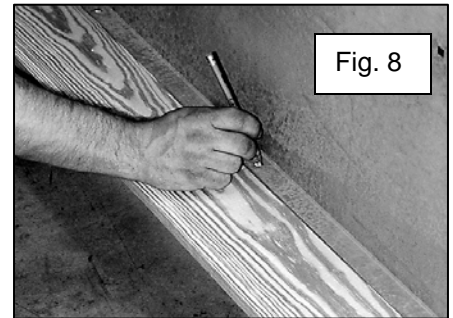

11. Install the edge boards underneath the bed side lower lip as in step #8. Place 5/16"-18 x 1-1/2" carriage bolts through the bed side and the boards. See figure 10. Leave off the lock washers and nuts for now. Also leave each hole in the bed sides at the rear of the bed empty for now.

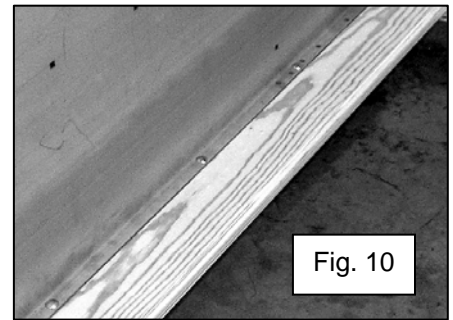

12. Attach the front s-shaped cross sill to the first 5/16" carriage bolt from the front of the bed on each bed side. The holes in the front panel lower lip and the s-shaped cross sill should line up to this position on the bed side. The front bed panel lower lip should be on top of the sill. The u-shaped brackets should be facing toward the rear of the bed. See figure 11. Install lock washers and nuts hand tight.

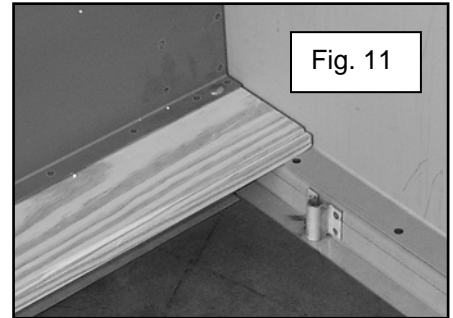

13. Attach a center cross sill to the 5/16" carriage bolts approximately 25" from the front bed panel. This cross sill should be installed with the opening facing downward and the shorter leg of the cross sill facing the rear of the bed toward the tailgate. See figure 12. Install lock washers and nuts hand tight.

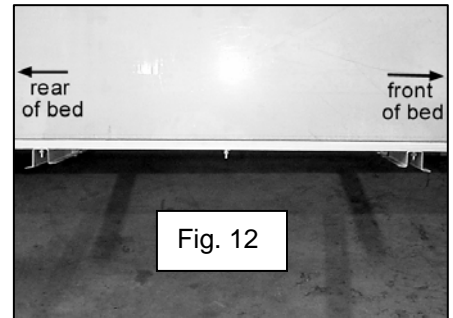

14. Attach the second center cross sill to the 5/16" carriage bolts approximately 53-7/8" from the front bed panel. This cross sill installs like the first center cross sill except that it is turned around with the shorter height cross sill leg toward the cab. See figure 12.

15. Install the second board next to each edge board leaving approximately a 1/2" gap between them. See figure 13. These boards will have the rear machined recess on them for the rear wood sill protector as well.



Note: May have to recess area on bottom of wood for front sill bracket. This is necessary to clear the bracket.

16. Place a bed strip between these boards. See figure 14. Install the 5/16"-18 x 1-1/2" carriage bolts through the bed strip's square holes into the cross sills, front bed panel, and rear cross sill. Install the lock washers and nuts hand tight. The bed strip pattern should match closely to the bedside lower flange pattern. *If using MAR-K's custom bed strips with hidden fasteners, follow the instructions supplied with the bed strips for correct installation.*

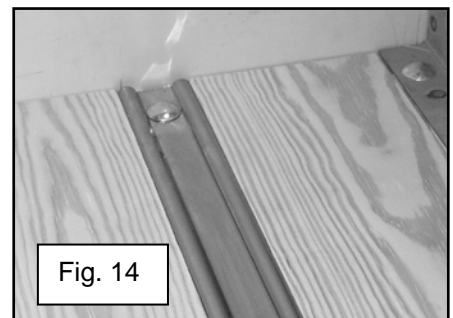

Note: You may notice that the bed strips are shorter than the wood boards. The rear wood sill protector is used at the rear of the bed to cover the end of the wood boards and also to hold them down.

Note:The next step is to drill and countersink the locations for the bed-to-frame bolts and washers that sit on the top of the wood surface. If wood was purchased with the holes predrilled, skip to step #25. If wood was purchased without holes, the following steps will direct you through this process.

17. Mark the first bed-to-frame hole through the front cross sill brackets.

18. The second bed-to-frame bolt location is in the first center cross sill. Mark the bottom of both boards through the 5/8" diameter cross sill holes that are **31-1/2"** apart from center of hole to center of hole. See figure 15.

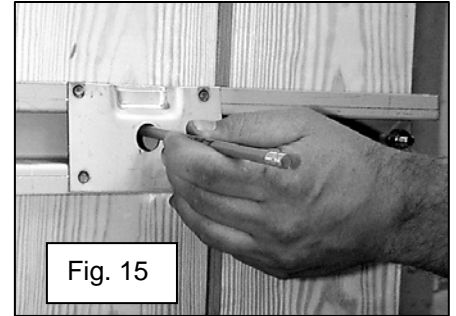

19. The third bed-to-frame bolt location is in the other center cross sill. Mark the bottom of the wood boards through the 5/8" diameter cross sill holes that are **31-1/2"** apart from center of hole to center of hole.

20. Make reference as to which end of each board is at the front of the bed. Remove the bed strips and the two inner boards. The bottom side of these boards should now have three 5/8" diameter holes marked on each of them.

21. Drill a 1/8" diameter pilot hole through the center of these marks completely through the boards.

22. On the top surface of the wood boards, countersink each location approximately 1/8" to 5/32" deep. Use a 1-7/8" diameter Forstner bit and a drill press if available. A hand drill could be used but it is not recommended. See figure 16.

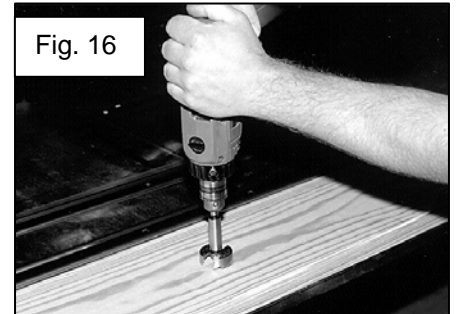

23. Using the same 1/8" pilot holes as a guide, drill through the boards with a 5/8" wood bit to complete the bed-to-frame holes. See figure 17. You may wish to enlarge the top of the 5/8" hole so that the bed-to-frame washer will sit in the countersink properly.

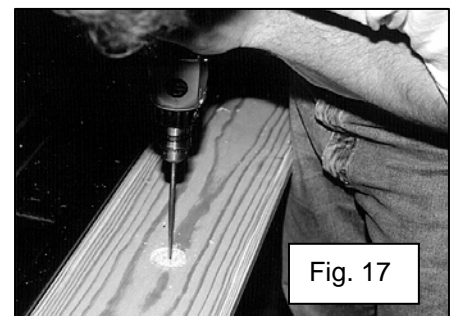

24. Reinstall these boards and bed strips as before. Check that the wood holes and strip holes line up to the cross sill bed-to-frame holes on the front cross sill and center cross sills.

25. Where there is not a cross sill attached to the bed side lower lip bolts, install a 1" outside diameter flat washer with a 5/16" diameter hole on the bottom of the wood surface before installing lock washers and nuts hand tight. See figure 18.

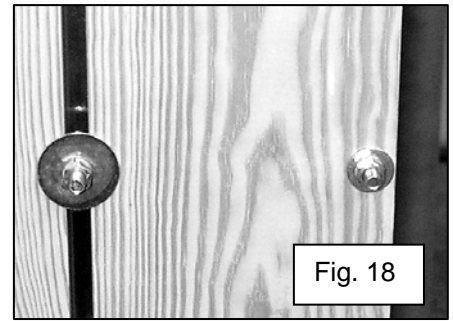

26. Where there is not a cross sill under the bed strip bolt, install a 1-1/2" outside diameter washer with a 5/16" diameter hole before installing lock washers and nuts. See figure 18.

27. Continue installing boards and strips from both sides working toward the center. Remember that the boards are machined at the rear of the bed for the bed wood sill protector. See figure 19. Adjust the gaps between the bed strips and the boards before tightening the bolts. Do not over tighten or broken bolts and damaged bed strips may occur.

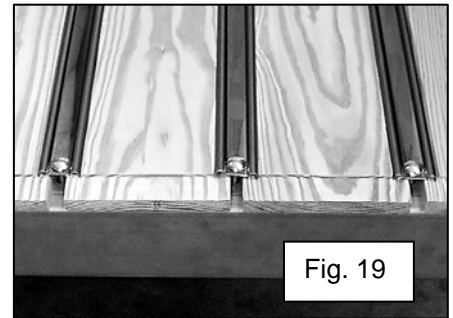

28. Install the bed wood sill protector. The ends of this part should fit under the rear corner of the bed sides lower lips and cap the ends of the wood boards. See figure 20. The rear 5/16"-18 x 1-1/2" carriage bolts in the bed sides were left out for this reason. The two center bolt locations in the bed wood sill protector will need to be transferred to and drilled through the wood boards. These two center 5/16"-18 x 1-1/2" carriage bolts in the bed wood sill protector bolt through the wood boards and into the rear cross sill. The hardware needed is provided in the bolt kit for the floor.

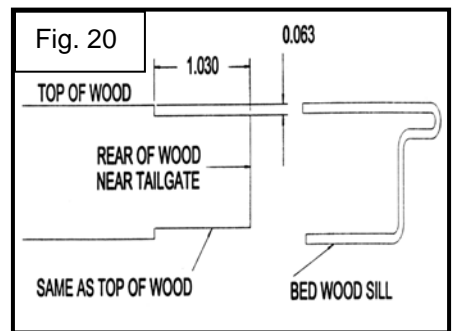

29. Remove the 1/4"-20 x 2-3/4" bolts securing the rear cross sill to the rear stake pockets. These bolts also hold the tailgate hinges in place. Install one tailgate hinge onto the left rear stake pocket. Use the bolt just removed from the lower hole and a 1/4"-20 x 5/8" bolt for the upper hole. See figure 21. This upper bolt will thread into a nut welded inside the stake pocket.

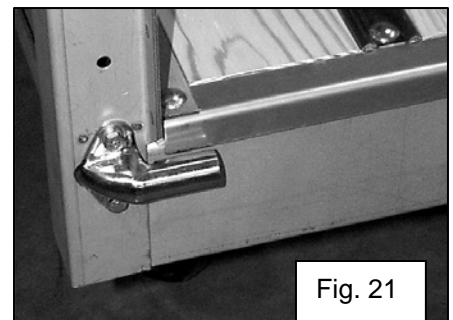

30. Install the right side hinge into the tailgate end. Place the tailgate onto the left hinge while bolting the right hinge to the right rear stake pocket. See figure 22. Use the same hardware on the right side including the 1/4"-20 x 5/8" hex bolt and the 1/4"-20 x 2-3/4" hex bolt, lock washer, and nut on the lower hole.

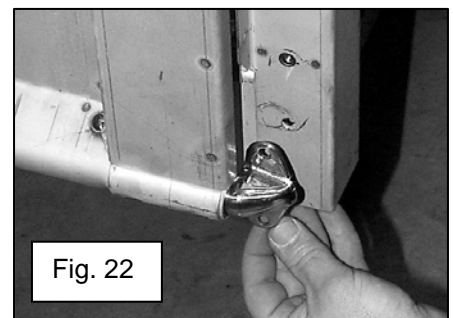

Note:The 51-52 tailgate is different than the one pictured.

31. Install the tailgate chain eyebolts into the rear stake pockets and secure with the 3/8" lock washers and nuts. Close tailgate and latch shut. See figure 23.

Note: The 51-52 tailgate and tailgate chains are different than the ones pictured.

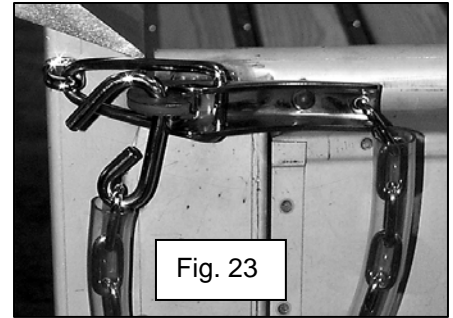

32. Install the completed bed assembly to the truck frame. This will enable you to check the alignment of the bed-to-frame bolt locations. You may wish to use a rubber pad between all mounting points of the frame and bed assembly. See figure 24.

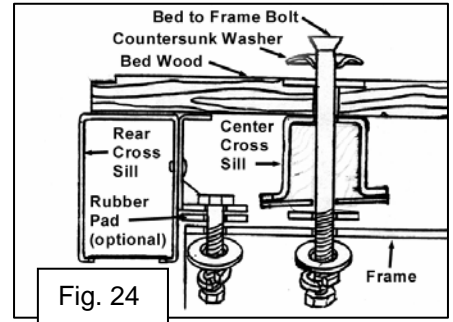

33. After checking the alignment of the bed assembly to the cab and frame mounting holes, install the bed-to-frame bolts. There will be 6 bolts (2 at front and 4 in center with special washers). See figure 23. Install the flat washers, lock washers, and nuts on the bottom side. The rear sill bolts directly to the frame under the wood surface. These bolts are not provided in our floor kit.

34. You may wish to bolt the front bed panel side flanges to the bed sides. This area may have been riveted or spot welded originally. If using bolts or rivets, you will need to drill through the front bed panel and bed sides for a 1/4" bolt. Measure up from the bottom lip of the front bed panel 1-1/2" and in from the outside surface of the front bed panel toward the stake pocket 1/2" and mark the hole.

35. Make sure that your front bed panel is straight up and down in relation to the bed sides. Center punch this mark and then drill through the front bed panel and bed side with a 9/32" drill. The next three should be spaced from the bottom bolt at 5-1/4" increments. There should be four bolts or rivets per side.

36. Bolt the front bed panel side flanges to each bed side through these holes with 1/4"-20 x 5/8" hex head bolts, lock washers, and nuts.

37. You have assembled the entire bed. Check all parts for correct fit and alignment. Be sure the bolts are in place and that all dimensions are correct. Now remove the bed from the frame and disassemble the parts to prepare for painting.

FINAL ASSEMBLY

After the parts are painted, the bed is assembled by the same procedure. By taking the time to assemble and test fit the bed before painting, you have reduced the chances for errors or problems in final assembly.

©Copyright 1999 MAR-K Quality Parts, L.L.C. All rights reserved.



FACTS ABOUT OUR PARTS

Stainless Steel: Bed strips, angle strips, and stainless mouldings are made of type 430 or 434 bright stainless steel, selected because of its color. It is a magnetic grade of stainless formulated for automotive stainless steel trim. When it is polished and buffed, its bright color looks similar to chrome plating. Stainless hardware items such as bolts, nuts, tailgate chain parts, and bed-to-frame washers are made of nonmagnetic stainless selected for superior resistance to rust and corrosion.

Care of Stainless / Rusting: With proper care, stainless steel will remain bright and smooth for long periods of time. It may be cleaned with liquid polish intended for stainless or chrome. DO NOT use steel wool, a steel wire brush, or a buffing wheel which has been used on steel or other metals. Bright stainless parts should be coated with a good nonabrasive wax for maximum protection. Stainless steel will rust or corrode under certain conditions, especially when contaminants such as salt water, battery acid, or steel particles and moisture are present. Frequent washing and waxing are a great protection against damage to stainless steel surfaces.

Electro-galvanized Steel: Many of the sheet metal parts MAR-K manufactures are made of electro-galvanized steel. This means the metal is electroplated with a thin layer of zinc by the steel manufacturer. There are several reasons for selecting this steel for our product.

1. Electro-galvanized steel is clean and dry.
2. The zinc protects our parts from rusting during our processing and while on the shelf.
3. After the parts are painted, the zinc under the paint helps prevent loss of paint adhesion or rusting if the paint surface is scratched or damaged.

Preparing Parts for Painting: The objectives of painting a part are to protect the metal and to provide a beautiful colored surface. No matter how beautiful the paint, if it doesn't stick to the surface, it will not be satisfactory. Excellent paint adhesion to a metal surface depends mainly on two things, the quality and characteristics of the primer used, and how well the surface is cleaned and prepared for painting. Prepare the surface as follows to help the paint have the best adhesion possible.

Steps for Excellent Paint Adhesion on MAR-K parts

The following steps are a general guideline to obtain excellent paint adhesion to your new parts

1. Select the primer product with the best adhesion properties within the paint system you are using. Products such as PPG "DPLF Epoxy Primer", Sherwin Williams G.B.P. Etching Filler or Etching Primer, and DuPont Variprime 615S/625S Self-Etching Primer will provide excellent adhesion to MAR-K metal parts that have been properly prepared for painting.

2. Wipe the part with solvent such as PPG DX330 Wax and Grease Remover, Sherwin Williams R7K156 Solvent Cleaner, or DuPont 3919S Prep-Sol to remove grease and lubricants from the manufacturing process.
3. Scrub all surfaces of the part with mild detergent in hot water. Rinse well and wipe dry with a clean dry cloth.
4. Wipe the part again with solvent as in step 2 above. The surface must be absolutely clean before sanding to prevent the sanding process from spreading the contaminants or imbedding them into the surface.
5. Scuff sand all areas to be painted using progressively finer grit to about 240 grit paper. Do not try to completely remove or sand through the zinc plating, but the complete part must be thoroughly sanded for best paint adhesion. Use a "DA" sander for broad flat areas and hand sanding for areas that can't be reached with the power sander.
6. Wash and rinse away all sanding residue. Use compressed air to blow the rinse water out of all seams and dry the parts with a clean towel. If the rinse water beads up anywhere on the surface, it is not clean and the solvent wipe and water washing steps must be repeated and additional sanding may be required in that area.
7. Wipe with solvent such as PPG DX330, Sherwin Williams R7K158, or DuPont 3901S to remove any traces of contaminants or sanding residue. Wipe the surface dry with a clean cloth. Do not allow the solvent to evaporate dry on the surface. Wet it again if it should evaporate dry.
8. The parts should be ready for prime painting. PPG recommends a final wipe with a clean damp cloth to remove any residue left from evaporation of the solvent. A quick wipe with a tack rag right before priming helps remove any remaining dust.
9. Immediately after cleaning and drying the parts as above, apply the primer according to the manufacturer's instructions for the products you are using. The recommended drying time between coats is especially important.

Some other helpful hints for a successful paint job.

1. Be sure to use fresh paint products that are top quality from a reputable manufacturer. Do not try to economize by using inferior or leftover paint materials.
2. Select all the products for a paint job from a single manufacturer and do not mix different systems within a brand of paint. Use only products that are intended to be used together.
3. Do not use the same air hoses on your paint gun that are also used with air tools such as sanders and air wrenches. Oil in the air tools will find its way into the hose and be a source of contamination for the paint. New hoses contain oils and other contaminants and should be cleaned before use on a paint gun.
4. Wear clean latex or nitrile gloves to prevent fingerprint oils from contaminating the surfaces of your cleaned parts.
5. Plan to prime the parts immediately after cleaning and sanding to prevent any bare steel areas from developing surface rust or the parts from becoming contaminated again.
6. Obtain a technical data sheet for each product being used and read and follow the instructions. The manufacturer's data sheet will provide specific instructions that apply to the product being used. These are available on-line or from your paint supplier.

©Copyright 2007 MAR-K Quality Parts L.L.C. All rights reserved.