

# MAR-K

RESTORATION AND CUSTOM PICKUP PARTS

## BED PARTS ASSEMBLY GUIDE 67-72 GM LONG FLEETSIDE WITH WOOD FLOOR

If you have not yet disassembled your original bed, make notes and sketches and take pictures of part locations to aid in the assembly procedure. This instruction gives information regarding the assembly of a wood floor bed. Use the following steps to assemble the entire bed to test fit all of the parts.

1. Begin with one bed side and the front bed panel. Bolt the front bed panel flange to the inside of the bed side with (3) 5/16"-18 x 3/4" indented hex washer head bolts with 5/16" lock washers and nuts in the bottom three holes. Use (2) 5/16"-18 x 3/4" phillips pan head machine screws through the top two holes into the curl area of the front bed panel. These thread into the welded nut plate in the curl. See figure 1.

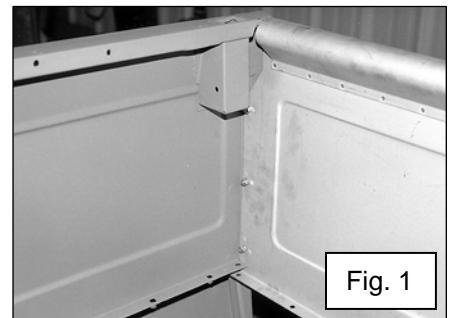

2. Finish bolting the front bed panel to the other bed side in the same manner.

3. Fit the rear cross sill into the rear stake pockets that are part of the bed sides. The large brackets of the rear cross sill should be facing the front bed panel and the open side of the rear sill should be facing open to the ground. See figure 2.

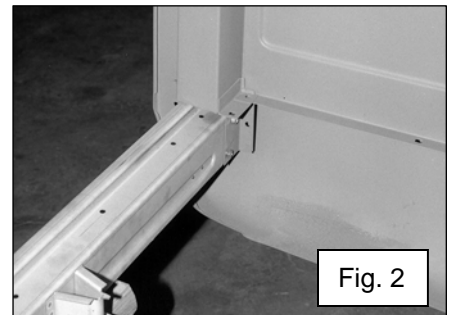

4. Bolt in place using (8) 5/16"-18 x 3/4" indented hex washer head bolts, (4) 5/16" lock washers, and (4) 5/16" nuts.

5. Once the four pieces of the bed are assembled, make sure the bed is square. Measure from the front of one bed side to the rear of other bedside in a crosswise pattern. Do this in both directions. These measurements should be within 1/16" from each other.

6. Measure the bed width at the top and bottom of the bedsides to ensure that they are straight up and down and are 72" apart inside. Now tighten all bolts.

7. Place the assembly horizontally to gain access to both the top and bottom of the floor area.

8. Re-install wheel well if removed. The bottom lip of wheel well sits on top of the bedside lower flange. The wheel well is held in place with 5/16"-18 x 3/4" indented hex washer head bolts as needed. See figure 3.

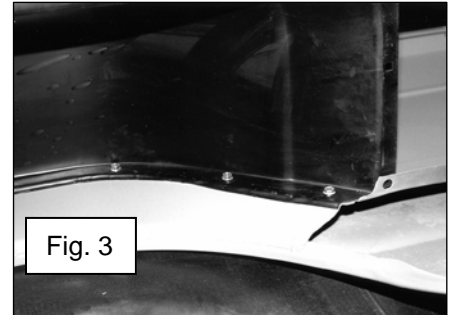

**Note:** The following sequence of steps #9 through #14 are for locating and drilling of all holes needed in the boards that attach to the bedsides and the wheel houses.

9. Install the short wood boards under the lower flange on bed sides in front and behind the wheel well. The front board will rest on the lower flange of the front bed panel. The rear board will rest on the rear cross sill ledge.

10. Install the long boards with the wheel well cutout under the bed side wheel well.

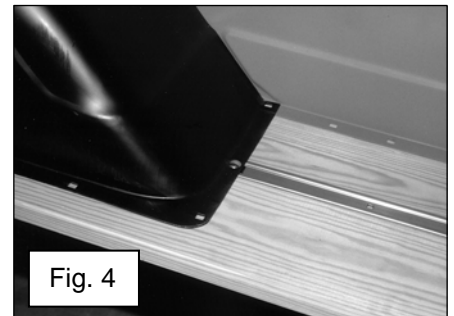

11. Place the short bed strips between these boards to ensure the right spacing. The bed strips will slide under the wheel well but on top of the boards. *If using MAR-K's custom bed strips with hidden fasteners, follow the instructions supplied with the bed strips for correct installation.*

12. Install a 5/16"-18 x 1-1/2" carriage bolt through the wheel well and through the bed strip. Use a 1-1/2" outside diameter flat washer and 5/16" nut to hold the short wood boards to the wheel well. See figure 4.

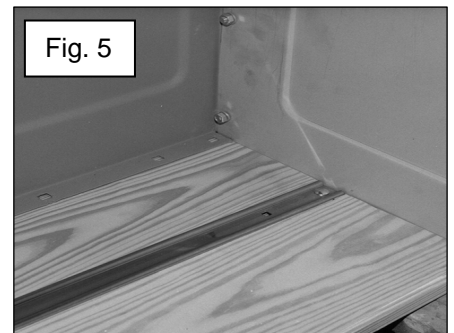

13. Install a 1/4"-20 x 1-1/4" carriage bolt through the rear bed strip to the rear cross sill and a 5/16"-18 x 1-1/2" carriage bolt through the front bed strip to the front bed panel lower flange. Minimize the gaps between the bed strips and the bed wood grooves and hand tighten bolts. See figure 5.

14. Mark the hole locations through the bed side lower flange and the wheel house lower flange onto the wood boards. See figure 6.

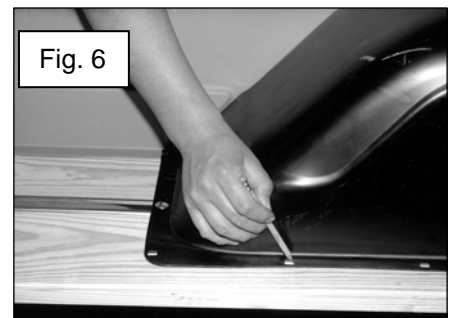

15. Remove these boards and drill these holes with a 3/8" drill.

16. Replace the boards and install 5/16"-18 x 1-1/2" carriage bolts through the bedside lower flange and the wheel house lower flange through the boards. Leave the lock washers and nuts off of these bolts for now. Also reinstall the bolts at the end of the short strips with lock washers and nuts.

17. Attach the cross sills to these bolts from the bed side lower flanges and the short bed strips. See figure 7. The first cross sill connects to the second bed strip hole that is **3-3/8** inches back from the front of the bed. The second cross sill connects to the third bed strip hole that is **15-3/8** inches back from the front. The third cross sill attaches to the bed strip hole **26-3/4** inches from the front of the bed. The fourth cross sill connects to the eighth bed strip hole at **72-1/2** inches from the front, which coincides with the rear of the wheel well. The fifth cross sill connects to the ninth bed strip hole at **83** inches from the front. There are two smaller cross members located at the front or beginning of the wheel well and at **60-1/8** inches from the front of the bed. One reinforcement strip is 72" and one is 49-1/2". Attach these reinforcement strips to the bolts from the bed sides and the wheel well. Mount the 72" at the front of the wheel well and the 49-1/2" reinforcement strip fits between the wheelhouses at **60-1/8** inches.



**Note:** The following steps #18 through #22 are a guideline for locating and drilling the wood boards for the bed-to-frame locations. If your wood has these holes pre-drilled, then skip to step #27. If not, steps #18 through #26 will direct you through this process.

18. Install the next board and bed strip on each side. Hand tighten the carriage bolts.

19. Mark through the 1/2" diameter holes in the cross sills onto the bottom of the wood boards. See figure 8. There may be more than one pair of 1/2" diameter holes supplied in the sill, so make sure of the frame spacing for that particular cross sill. The first and fourth cross sill frame spacing should be **31-3/4** inches apart. The third cross sill from the front has a frame spacing of **37-3/4** inches.

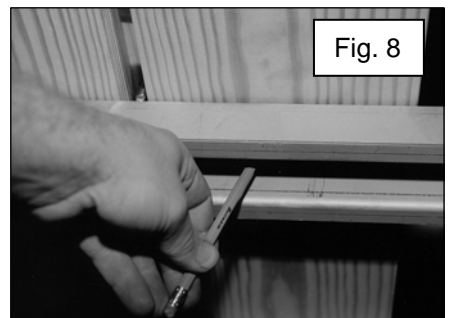

20. The rear cross sill also receives a bed-to-frame bolt. Mark the boards through the rear cross sill brackets. See figure 9.

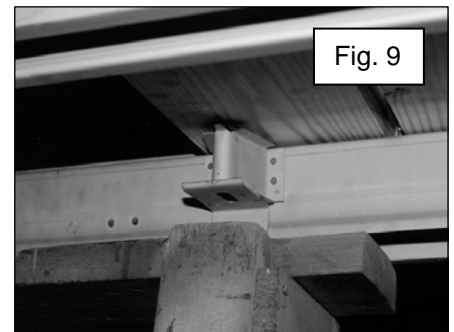

21. Make reference as to which end of the board was at the front bed panel. Remove these two boards. There should be four 1/2" diameter holes marked on the bottom of each board. The marks made through the rear cross sill should be **93-3/8** inches from the front and should be in line with the marked location at 72-1/2 inches.

22. Drill a 1/8" pilot hole completely through the boards in the center of each of the marked locations.

23. Turn the boards over and measure forward from the pilot holes exactly 3/16" towards the front of the board and make a mark. See figure 10.

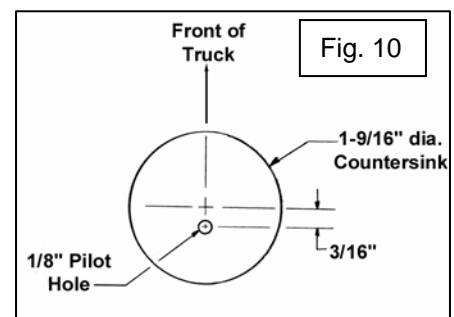

24. Using a 1-9/16" Forstner bit with a 3/8" diameter shank, a drill press if available, or a hand drill, countersink each bed-to-frame location approximately 1/8" to 3/16" deep on each mark from step #23. See figure 11. This offset hole is for the offset washer. The offset washer keeps the bolt from turning.



25. To finish this procedure, drill a 1/2" hole through the boards using the pilot holes drilled in step #22 as a guide. See figure 12.

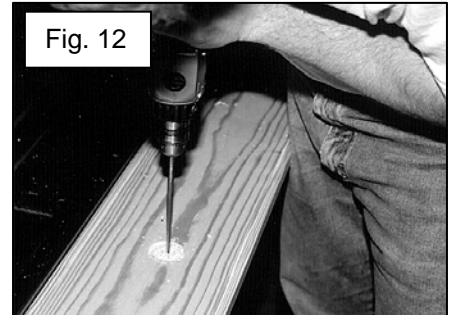

26. Reinstall the mounting hole boards and the bed strips. See figure 13.

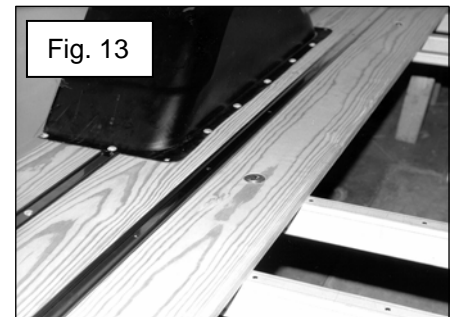

27. Install the remaining boards and bed strips following the symmetrical pattern in the cross sill. Recheck the bed-to-frame bolt spacing in the bed and compare it to the truck frame. Tighten all bolts.

28. Install the front bed side fender braces. These bolt to the first cross sill in front of the wheel tub and the bed side. Measure in from the end of the cross sill 13-1/8" and up from the bottom 15/16" and mark the sill. This mark should be on the front side of the cross sill towards the front bed panel. Drill a 3/8" hole where marked. Bolt fender brace to sill. See figure 14.

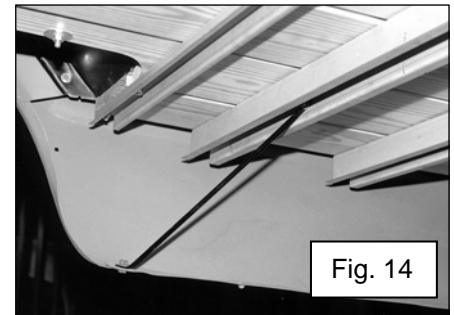

29. Attach rear wheel splash aprons to bed sides. Bolt splash apron to bed side first. Align two holes in splash apron to lower rear leg of cross sill and mark holes through splash apron. Remove splash apron and drill these two holes with a 3/8" drill. Replace splash apron with four bolts. See figure 15.

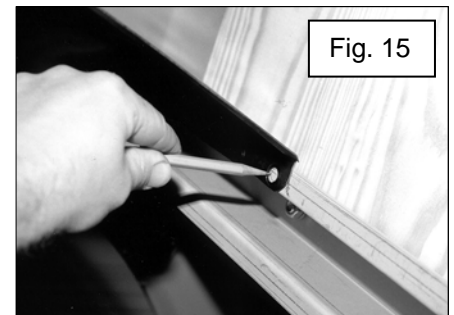

30. Install the wiring harness into the rear cross sill and up through the rear stake pockets on the bed sides. **(Hint:)** To pull the wiring up through the stake pockets, feed a metal wire down through the taillight opening. Attach to the taillight and back-up light wires and pull them up to the opening.
31. Connect the side marker light, back-up light, and taillight wiring to their sockets. Bolt the bezels to the bed sides. Replace the bulbs and the lenses.
32. Place the completed bed assembly back onto the truck frame. Bolt the bed down using the bed-to-frame bolts.
33. Connect the main wiring harness junction and test the lights.

©Copyright 2002 MAR-K Quality Parts L.L.C. All rights reserved.



### FACTS ABOUT OUR PARTS

**Stainless Steel:** Bed strips, angle strips, and stainless mouldings are made of type 430 or 434 bright stainless steel, selected because of its color. It is a magnetic grade of stainless formulated for automotive stainless steel trim. When it is polished and buffed, its bright color looks similar to chrome plating. Stainless hardware items such as bolts, nuts, tailgate chain parts, and bed-to-frame washers are made of nonmagnetic stainless selected for superior resistance to rust and corrosion.

**Care of Stainless / Rusting:** With proper care, stainless steel will remain bright and smooth for long periods of time. It may be cleaned with liquid polish intended for stainless or chrome. DO NOT use steel wool, a steel wire brush, or a buffing wheel which has been used on steel or other metals. Bright stainless parts should be coated with a good nonabrasive wax for maximum protection. Stainless steel will rust or corrode under certain conditions, especially when contaminants such as salt water, battery acid, or steel particles and moisture are present. Frequent washing and waxing are a great protection against damage to stainless steel surfaces.

**Electro-galvanized Steel:** Many of the sheet metal parts MAR-K manufactures are made of electro-galvanized steel. This means the metal is electroplated with a thin layer of zinc by the steel manufacturer. There are several reasons for selecting this steel for our product.

1. Electro-galvanized steel is clean and dry.
2. The zinc protects our parts from rusting during our processing and while on the shelf.
3. After the parts are painted, the zinc under the paint helps prevent loss of paint adhesion or rusting if the paint surface is scratched or damaged.

**Preparing Parts for Painting:** The objectives of painting a part are to protect the metal and to provide a beautiful colored surface. No matter how beautiful the paint, if it doesn't stick to the surface, it will not be satisfactory. Excellent paint adhesion to a metal surface depends mainly on two things, the quality and characteristics of the primer used, and how well the surface is cleaned and prepared for painting. Prepare the surface as follows to help the paint have the best adhesion possible.

#### **Steps for Excellent Paint Adhesion on MAR-K parts**

The following steps are a general guideline to obtain excellent paint adhesion to your new parts

1. Select the primer product with the best adhesion properties within the paint system you are using. Products such as PPG "DPLF Epoxy Primer", Sherwin Williams G.B.P. Etching Filler or Etching Primer, and DuPont Variprime 615S/625S Self-Etching Primer will provide excellent adhesion to MAR-K metal parts that have been properly prepared for painting.

2. Wipe the part with solvent such as PPG DX330 Wax and Grease Remover, Sherwin Williams R7K156 Solvent Cleaner, or DuPont 3919S Prep-Sol to remove grease and lubricants from the manufacturing process.
3. Scrub all surfaces of the part with mild detergent in hot water. Rinse well and wipe dry with a clean dry cloth.
4. Wipe the part again with solvent as in step 2 above. The surface must be absolutely clean before sanding to prevent the sanding process from spreading the contaminants or imbedding them into the surface.
5. Scuff sand all areas to be painted using progressively finer grit to about 240 grit paper. Do not try to completely remove or sand through the zinc plating, but the complete part must be thoroughly sanded for best paint adhesion. Use a "DA" sander for broad flat areas and hand sanding for areas that can't be reached with the power sander.
6. Wash and rinse away all sanding residue. Use compressed air to blow the rinse water out of all seams and dry the parts with a clean towel. If the rinse water beads up anywhere on the surface, it is not clean and the solvent wipe and water washing steps must be repeated and additional sanding may be required in that area.
7. Wipe with solvent such as PPG DX330, Sherwin Williams R7K158, or DuPont 3901S to remove any traces of contaminants or sanding residue. Wipe the surface dry with a clean cloth. Do not allow the solvent to evaporate dry on the surface. Wet it again if it should evaporate dry.
8. The parts should be ready for prime painting. PPG recommends a final wipe with a clean damp cloth to remove any residue left from evaporation of the solvent. A quick wipe with a tack rag right before priming helps remove any remaining dust.
9. Immediately after cleaning and drying the parts as above, apply the primer according to the manufacturer's instructions for the products you are using. The recommended drying time between coats is especially important.

**Some other helpful hints for a successful paint job.**

1. Be sure to use fresh paint products that are top quality from a reputable manufacturer. Do not try to economize by using inferior or leftover paint materials.
2. Select all the products for a paint job from a single manufacturer and do not mix different systems within a brand of paint. Use only products that are intended to be used together.
3. Do not use the same air hoses on your paint gun that are also used with air tools such as sanders and air wrenches. Oil in the air tools will find its way into the hose and be a source of contamination for the paint. New hoses contain oils and other contaminants and should be cleaned before use on a paint gun.
4. Wear clean latex or nitrile gloves to prevent fingerprint oils from contaminating the surfaces of your cleaned parts.
5. Plan to prime the parts immediately after cleaning and sanding to prevent any bare steel areas from developing surface rust or the parts from becoming contaminated again.
6. Obtain a technical data sheet for each product being used and read and follow the instructions. The manufacturer's data sheet will provide specific instructions that apply to the product being used. These are available on-line or from your paint supplier.

©Copyright 2007 MAR-K Quality Parts L.L.C. All rights reserved.