

MAR-K

RESTORATION AND CUSTOM PICKUP PARTS

BED PARTS ASSEMBLY GUIDE 41-46 CHEVY 3/4 TON LONG STEPSIDE

If you have not yet disassembled your original bed, make notes and sketches and take pictures of part locations to aid in the assembly procedure. Use the following steps to assemble the entire bed to test fit all parts.

1. Begin with one bed side and the front bed panel. Bolt the front bed panel flange to the inside of the bed side with (4) 1/4"-20 x 5/8" hex head bolts, lock washers, and nuts from the front bed panel mounting kit. See figure 1.
2. This bed requires the use of a long rod that attaches through the front bed panel top curl to the bed sides. Install a 5/16" flat washer, lock washer, and nut on one end of the rod. Insert the rod through the top hole in bed side into top curl of front bed panel.
3. Align and install the loose end of the rod through the other bed side and secure with a 5/16" flat washer, lock washer, and nut. See figure 2.
4. Bolt the front bed panel to the other bed side with (4) 1/4"-20 x 5/8" hex bolts, lock washers, and nuts.
5. Fit the rear cross sill inside the lower portion of the rear stake pockets with the open side of the rear cross sill facing downward. See figures 3 and 4. The flanged side of the rear cross sill faces toward the front bed panel.
6. Using (8) 5/16"-18 x 3/4" hex head bolts, lock washers, and nuts, bolt the rear cross sill to the stake pockets. Use the bottom (4) holes in each rear stake pocket only for now.

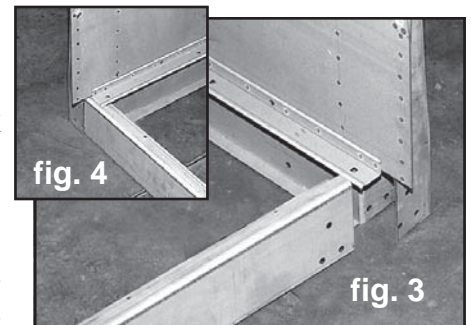
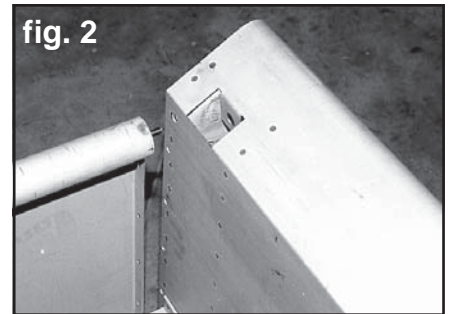
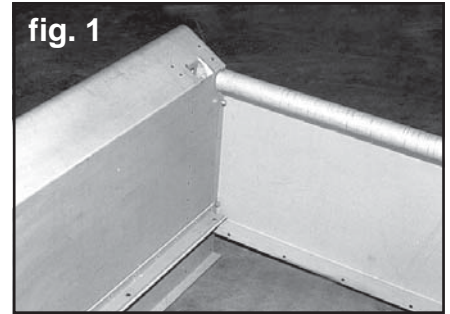

7. Once these four pieces of the bed are assembled, you will need to make sure the bed is square. Measure the bed width at the top and bottom of bed sides to ensure that the bed sides are straight up and down and are **48-1/2"** apart. Tighten the rear cross sill bolts. See figure 5.



8. Also measure crosswise from the front of the bed to the opposite rear of the bed on both sides. These measurements should be within 1/16" of each other to ensure the bed is square. Now tighten all bolts. See figure 6.

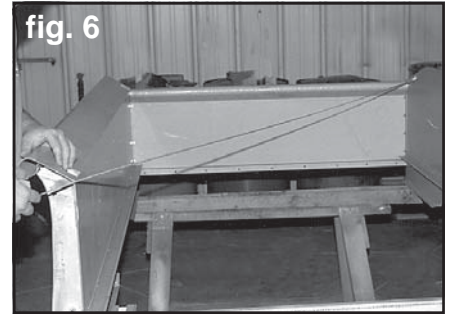

9. Place the assembly on supports horizontally to gain access to both the top and bottom of the floor area. See figure 7.

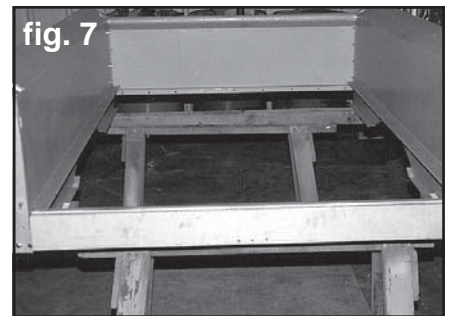

10. Place the wood boards that have only one bed strip groove (referred to as "edge boards") under the angle strips on the bed sides. The non-grooved edge should be toward the bed side. Leave approximately a 1/16" gap between the board and the bed side. See figure 8.

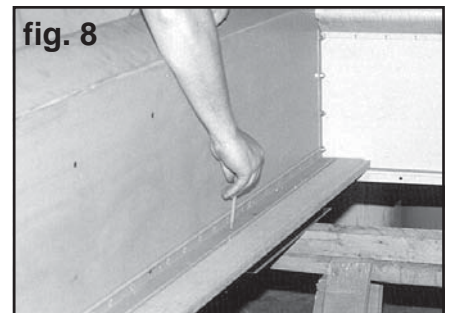

11. Mark all holes to be drilled into these boards through the angle strips square holes. See figure 8.

12. The fronts of the bed wood boards rest on top of the front bed panel lower flange. This flange bolts directly to the wood boards. Mark these holes through the front panel lower flange onto the bottom of these two boards. These holes should be approximately **5-3/8"** from both bed sides.

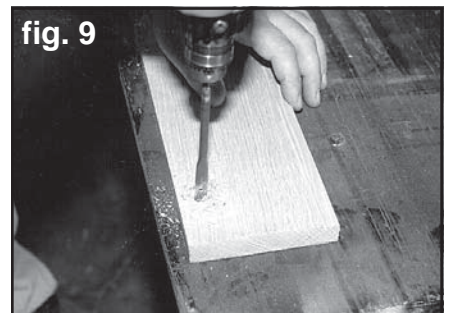

13. Remove these two boards and drill all holes marked using a 3/8" wood bit. Be careful not to splinter the other side of the board when drilling. Placing a wood block behind the board where drilling will help prevent this. See figure 9.

14. Install the edge boards underneath the angle strips as in step #10. Place 5/16"-18 x 1-1/2" carriage bolts through the angle strips and wood boards. See figure 10. Also place the same size bolt through the wood board and through the front panel lower flange. Leave off the lock washers and nuts for now.

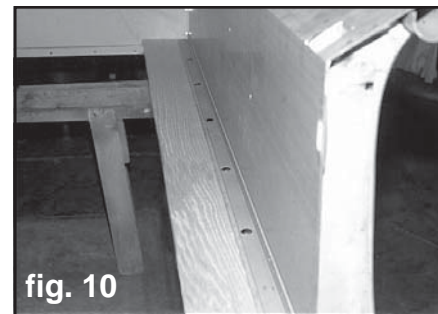

15. Slide the cross sill brackets on the cross sills and attach the cross sills to the 5/16" angle strip bolts approximately **2-3/4"**, **25-11/16"**, **40-7/16"** and **63-1/4"** from the front bed panel. See figure 11. Install lock washer and nut hand tight. The offset hole brackets go on the fourth cross sill and the hole is offset toward the bed sides.

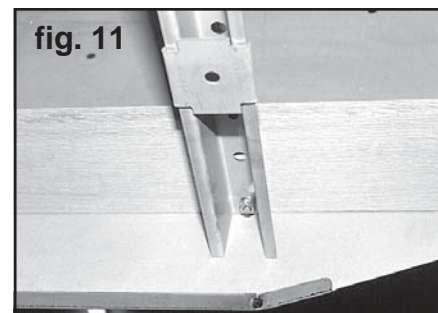

Note: The next step is to locate, drill, and countersink the locations for the bed-to-frame bolts and offset washers that sit on top of the wood surface. If wood was purchased with the bed-to-frame mounting holes predrilled, skip to step #25. If wood was purchased without these mounting holes, the following steps will direct you through this process.

16. The first cross sill near the front panel is the first bed-to-frame hole location. Mark the bottom of both side boards through the 1/2" diameter cross sill holes that are **34"** apart from center of hole to the center of hole. See figure 12.

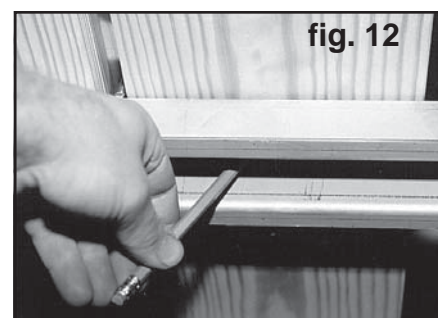

17. The second and fourth cross sills back from the front panel are also bed-to-frame bolt locations. Mark the bottom of the boards through the 1/2" diameter cross sill holes that are **34"** apart. The third cross sill back does not receive a bed-to-frame bolt.

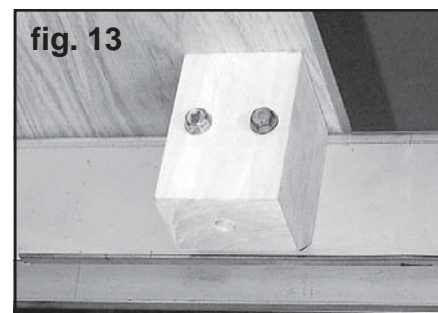

18. The fourth bed-to-frame bolt location is just in front of the rear cross sill. There are two large wood blocks that need to be bolted to the rear cross sill with (2) 5/16-18 x 4" hex head bolts, nuts and lockwashers per block. See figure 13. The angled cut on the wood block should be against the rear cross sill lower front lip. When installed, these blocks should fit against the bottom of the wood boards.

19. Mark the bottom of the wood boards through the large blocks. The spacing of these holes is identical to the cross sills mentioned earlier at **34"**. This mark should be **83-3/16"** back from the front of the wood boards at the front panel to the center of the hole.

20. Make reference as to which end of each wood board is at the front of the bed. Remove the cross sills and the boards. The bottom side of these boards should now have four 1/2" diameter round marks on each of them. Drill a 1/8" diameter pilot hole directly in the center of these marks completely through the boards.

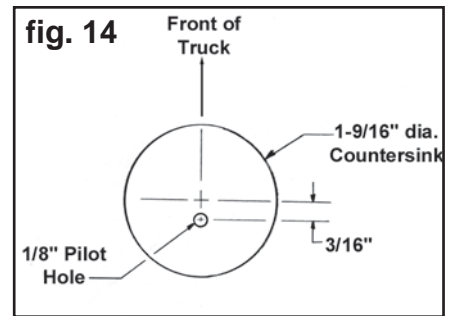

21. On the top of these boards measure toward the front of each board 3/16" from the center of each 1/8" diameter pilot hole and mark the board for the countersink. See figure 14.



22. Using a 1-9/16" diameter Forstner bit, a drill press if available, or a hand drill, countersink each location approximately 1/8" to 5/32" deep. See figure 15.

23. From the top surface of the boards, drill down through the 1/8" pilot holes with a 1/2" wood bit to complete the bed-to-frame mounting holes. See figure 16. Before drilling the hole, place a piece of scrap wood directly under the 1/8" hole to prevent splintering as the drill breaks through.

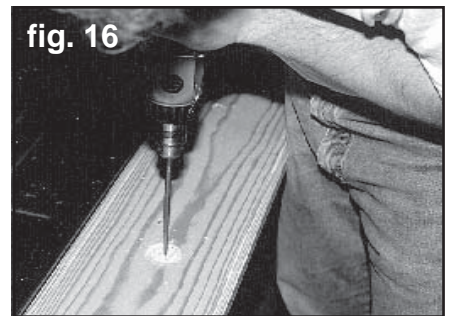

24. Reinstall the side boards. Before reinstalling the cross sills, tack weld the cross sill brackets in place in line with the bed-to-frame bolt locations. All brackets will need to line up with the bed-to-frame holes in the sills and the wood.

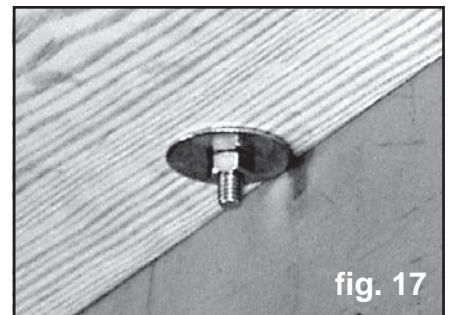

25. Where there is not a cross sill attached to the angle strip bolts, install a 1-1/2" outside diameter flat washer with a 5/16" diameter hole on the bottom of the wood board before installing lock washer and nut hand tight. See figure 17.

26. Install a 5/16" flat washer, lock washer, and nut onto the front bed panel bolts from the wood boards hand tight.

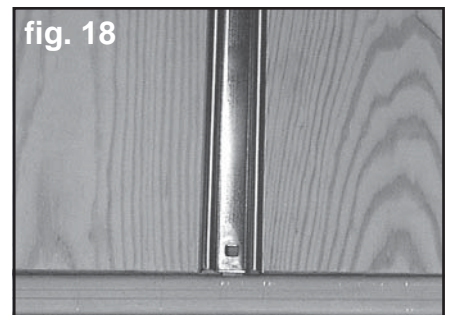

27. Place the next board into position on both sides leaving a 1/2" gap between boards. Place a bed strip in the grooves on top of the boards. The end of the strip with the hole closest to the end is positioned at the rear cross sill. See figure 18. The bed strip holes should line up to each cross sill location. Loosely install the 1/4"-20 x 1-1/4" carriage bolts, lock washers, and nuts into the bed strips. *Using MAR-K's custom bed strips with hidden fasteners, follow the instructions supplied with the bed strips for correct installation.*

Note: Where there is not a cross sill under the bed strip bolt, install a 1-1/2" outside diameter washer with a 1/4" diameter hole before installing lock washer and nut. See figure 19.

28. Continue installing boards and strips from both sides working toward the center. Adjust the gaps between the bed strips and the boards before tightening the bolts. Do not over tighten or broken bolts and damaged bed strips may occur.

29. Mark the front of the remaining boards through the bottom of the front bed panel lower flange as in steps #12 and #13. These holes will be drilled 3/8" diameter prior to wood finishing.

30. The next step is to install the completed bed assembly onto the frame of the truck. This will enable you to check the alignment of the bed-to-frame bolt locations. The order in which parts are installed on the frame is: rubber pad, wood mounting block, cross sill bracket/cross sill, and bed assembly. See figure 20. **Hint:** The small wood blocks with the offset hole are used at the fourth cross sill. The center hole blocks are used at remaining locations.

31. Align the bed assembly to the cab. Install the offset washers and the 3/8"-16 x 6" bed-to-frame bolts. When bed alignment is satisfactory, install the flat washers, lock washers, and nuts to the bed-to-frame carriage bolts.

32. Install one hinge to the passenger bed side rear stake pocket with two 5/16" hex head bolts, lock washers, and nuts. Fit the tailgate onto this hinge. Place the second hinge into the opposite end of the tailgate. Bolt this hinge to the driver rear stake pocket. See figure 21.

33. Install the tailgate chain eyebolts into the rear stake pockets. This model has a left and right chain assembly. See figure 22.

34. You have assembled the entire bed. Check all parts for correct fit and alignment. Be sure the bolts are in place and that all dimensions are correct. Now remove the bed from the frame and disassemble the parts to prepare for painting.

FINAL ASSEMBLY

After the parts are painted, the bed is assembled by the same procedure. By taking the time to assemble and test fit the bed before painting, you have reduced the chances for errors or problems in final assembly.

©Copyright 1999 MAR-K Quality Parts, L.L.C. All rights reserved.

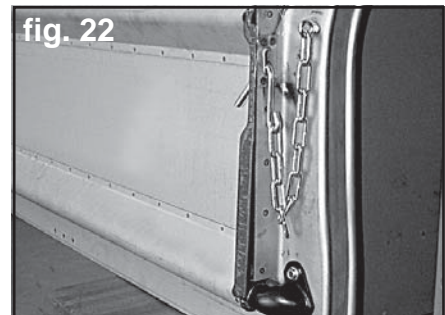
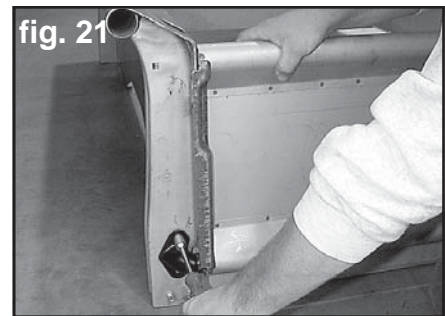
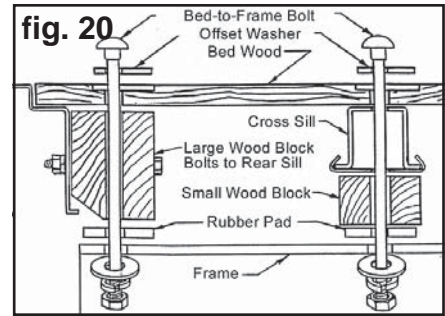
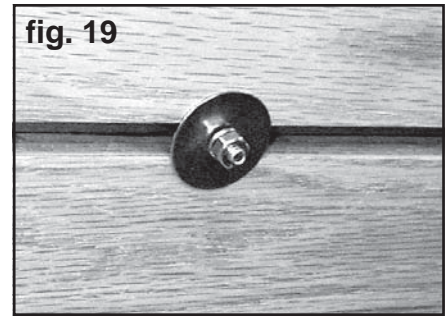



FACTS ABOUT OUR PARTS

Stainless Steel: Bed strips, angle strips, and stainless mouldings are made of type 430 or 434 bright stainless steel, selected because of its color. It is a magnetic grade of stainless formulated for automotive stainless steel trim. When it is polished and buffed, its bright color looks similar to chrome plating. Stainless hardware items such as bolts, nuts, tailgate chain parts, and bed-to-frame washers are made of nonmagnetic stainless selected for superior resistance to rust and corrosion.

Care of Stainless / Rusting: With proper care, stainless steel will remain bright and smooth for long periods of time. It may be cleaned with liquid polish intended for stainless or chrome. DO NOT use steel wool, a steel wire brush, or a buffing wheel which has been used on steel or other metals. Bright stainless parts should be coated with a good nonabrasive wax for maximum protection. Stainless steel will rust or corrode under certain conditions, especially when contaminants such as salt water, battery acid, or steel particles and moisture are present. Frequent washing and waxing are a great protection against damage to stainless steel surfaces.

Electro-galvanized Steel: Many of the sheet metal parts MAR-K manufactures are made of electro-galvanized steel. This means the metal is electroplated with a thin layer of zinc by the steel manufacturer. There are several reasons for selecting this steel for our product.

1. Electro-galvanized steel is clean and dry.
2. The zinc protects our parts from rusting during our processing and while on the shelf.
3. After the parts are painted, the zinc under the paint helps prevent loss of paint adhesion or rusting if the paint surface is scratched or damaged.

Preparing Parts for Painting: The objectives of painting a part are to protect the metal and to provide a beautiful colored surface. No matter how beautiful the paint, if it doesn't stick to the surface, it will not be satisfactory. Excellent paint adhesion to a metal surface depends mainly on two things, the quality and characteristics of the primer used, and how well the surface is cleaned and prepared for painting. Prepare the surface as follows to help the paint have the best adhesion possible.

Steps for Excellent Paint Adhesion on MAR-K parts

The following steps are a general guideline to obtain excellent paint adhesion to your new parts

1. Select the primer product with the best adhesion properties within the paint system you are using. Products such as PPG "DPLF Epoxy Primer", Sherwin Williams G.B.P. Etching Filler or Etching Primer, and DuPont Variprime 615S/625S Self-Etching Primer will provide excellent adhesion to MAR-K metal parts that have been properly prepared for painting.

2. Wipe the part with solvent such as PPG DX330 Wax and Grease Remover, Sherwin Williams R7K156 Solvent Cleaner, or DuPont 3919S Prep-Sol to remove grease and lubricants from the manufacturing process.
3. Scrub all surfaces of the part with mild detergent in hot water. Rinse well and wipe dry with a clean dry cloth.
4. Wipe the part again with solvent as in step 2 above. The surface must be absolutely clean before sanding to prevent the sanding process from spreading the contaminants or imbedding them into the surface.
5. Scuff sand all areas to be painted using progressively finer grit to about 240 grit paper. Do not try to completely remove or sand through the zinc plating, but the complete part must be thoroughly sanded for best paint adhesion. Use a "DA" sander for broad flat areas and hand sanding for areas that can't be reached with the power sander.
6. Wash and rinse away all sanding residue. Use compressed air to blow the rinse water out of all seams and dry the parts with a clean towel. If the rinse water beads up anywhere on the surface, it is not clean and the solvent wipe and water washing steps must be repeated and additional sanding may be required in that area.
7. Wipe with solvent such as PPG DX330, Sherwin Williams R7K158, or DuPont 3901S to remove any traces of contaminants or sanding residue. Wipe the surface dry with a clean cloth. Do not allow the solvent to evaporate dry on the surface. Wet it again if it should evaporate dry.
8. The parts should be ready for prime painting. PPG recommends a final wipe with a clean damp cloth to remove any residue left from evaporation of the solvent. A quick wipe with a tack rag right before priming helps remove any remaining dust.
9. Immediately after cleaning and drying the parts as above, apply the primer according to the manufacturer's instructions for the products you are using. The recommended drying time between coats is especially important.

Some other helpful hints for a successful paint job.

1. Be sure to use fresh paint products that are top quality from a reputable manufacturer. Do not try to economize by using inferior or leftover paint materials.
2. Select all the products for a paint job from a single manufacturer and do not mix different systems within a brand of paint. Use only products that are intended to be used together.
3. Do not use the same air hoses on your paint gun that are also used with air tools such as sanders and air wrenches. Oil in the air tools will find its way into the hose and be a source of contamination for the paint. New hoses contain oils and other contaminants and should be cleaned before use on a paint gun.
4. Wear clean latex or nitrile gloves to prevent fingerprint oils from contaminating the surfaces of your cleaned parts.
5. Plan to prime the parts immediately after cleaning and sanding to prevent any bare steel areas from developing surface rust or the parts from becoming contaminated again.
6. Obtain a technical data sheet for each product being used and read and follow the instructions. The manufacturer's data sheet will provide specific instructions that apply to the product being used. These are available on-line or from your paint supplier.

©Copyright 2007 MAR-K Quality Parts L.L.C. All rights reserved.